

owner's operating & installation manual

**PS520-Series OVENS
Model PS520E**

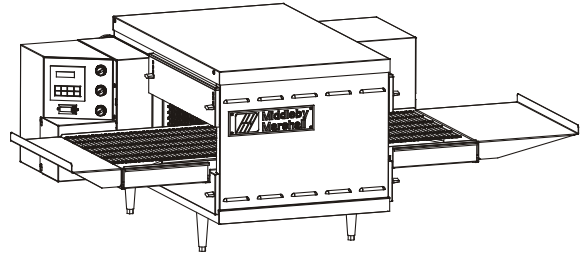

PS520 (Single)

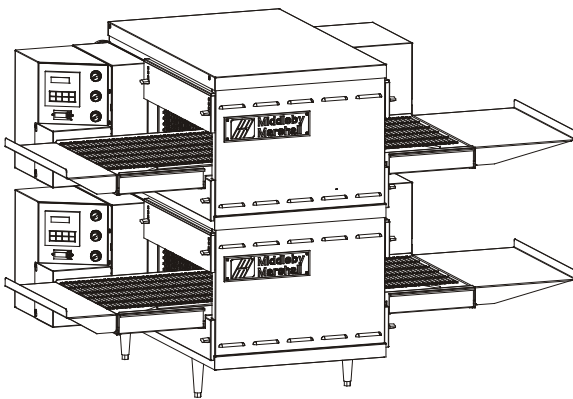

PS520 (Double)

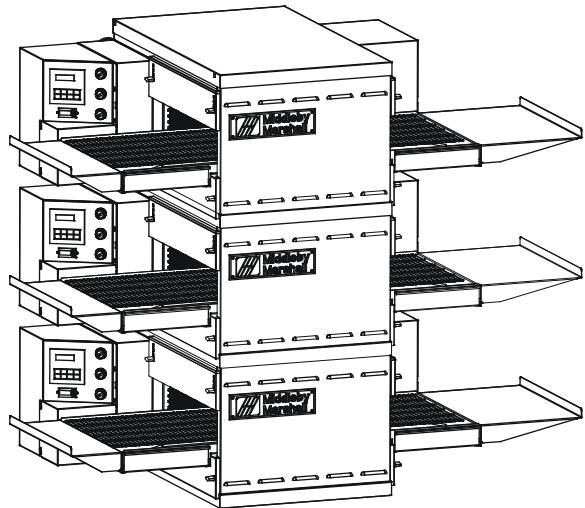

PS520 (Triple)



NOTICE:

This Owner's Operating and Installation Manual should be given to the user. The operator of the oven should be familiar with the functions and operation of the oven.

This manual must be kept in a prominent, easily reachable location near the oven.

It is suggested to obtain a service contract with a Middleby Marshall Authorized Service Agent.

WARNING

FOR YOUR SAFETY, DO NOT STORE OR USE GASOLINE OR OTHER FLAMMABLE VAPORS AND LIQUIDS IN THE VICINITY OF THIS OR ANY OTHER APPLIANCE.

WARNING

Improper installation, adjustment, alteration, service, or maintenance can cause property damage, injury, or death. Read the installation, operation, and maintenance instructions thoroughly before installing or servicing this equipment.

IMPORTANT

An electrical wiring diagram for the oven is located inside the machinery compartment.

IMPORTANT

It is the customer's responsibility to report any concealed or non-concealed damage to the freight company. Retain all shipping materials until it is certain that the equipment has not suffered concealed shipping damage.

NOTICE

Contact your Middleby Marshall Authorized Service Agent to perform maintenance and repairs. An Authorized Service Agency Directory is supplied with your oven.

NOTICE

Using any parts other than genuine Middleby Marshall factory manufactured parts relieves the manufacturer of all warranty and liability.

NOTICE

Middleby Marshall (Manufacturer) reserves the right to change specifications at any time.

NOTICE

The equipment warranty is not valid unless the oven is installed, started and demonstrated under the supervision of a factory certified installer.

NOTICE

A Middleby Marshall certified installer must be used to install and service this appliance.

NOTICE

This equipment is only for professional use and shall be used by qualified personnel.

CAUTION

In order to avoid a hazard due to inadvertent resetting of the thermal cut-out, this appliance must not be supplied through an external switching device, such as a timer, or connected to a circuit that is regularly switched on and off by the utility.

- i) This appliance is not Intended for use by persons (including children) with reduced physical, sensory or mental capabilities, or lack of experience and knowledge, unless they have been given supervision or instruction concerning use of the appliance by a person responsible for their safety.
- ii) Children should be supervised to ensure that they do not play with the appliance.
- iii) Cleaning and user maintenance shall not be made by children without supervision

RETAIN THIS MANUAL FOR FUTURE REFERENCE.

MIDDLEBY MARSHALL
NO QUIBBLE LIMITED WARRANTY
(U.S.A. ONLY)

MIDDLEBY MARSHALL, HEREINAFTER REFERRED TO AS "THE SELLER", WARRANTS EQUIPMENT MANUFACTURED BY IT TO BE FREE FROM DEFECTS IN MATERIAL AND WORKMANSHIP FOR WHICH IT IS RESPONSIBLE. THE SELLER'S OBLIGATION UNDER THIS WARRANTY SHALL BE LIMITED TO REPLACING OR REPAIRING, AT SELLER'S OPTION, WITHOUT CHARGE, ANY PART FOUND TO BE DEFECTIVE AND ANY LABOR AND MATERIAL EXPENSE INCURRED BY SELLER IN REPAIRING OR REPLACING SUCH PART. SUCH WARRANTY SHALL BE LIMITED TO THE ORIGINAL PURCHASER ONLY AND SHALL BE EFFECTIVE FOR A PERIOD OF ONE YEAR FROM DATE OF ORIGINAL INSTALLATION, OR 18 MONTHS FROM DATE OF PURCHASE, WHICHEVER IS EARLIER, PROVIDED THAT TERMS OF PAYMENT HAVE BEEN FULLY MET.

This warranty is valid only if the equipment is installed, started, and demonstrated under the supervision of a factory-authorized installer.

Normal maintenance functions, including lubrication, cleaning, or customer abuse, are not covered by this **no quibble warranty**.

Seller shall be responsible only for repairs or replacements of defective parts performed by Seller's authorized service personnel. Authorized service agencies are located in principal cities throughout the contiguous United States, Alaska, and Hawaii. This warranty is valid in the 50 United States and is void elsewhere unless the product is purchased through Middleby International with warranty included.

The foregoing warranty is exclusive and in lieu of all other warranties, expressed or implied. There are no implied warranties of merchantability or of fitness for a particular purpose.

The foregoing shall be Seller's sole and exclusive obligation and Buyer's sole and exclusive remedy for any action, including breach of contract or negligence. In no event shall Seller be liable for a sum in excess of the purchase price of the item. Seller shall not be liable for any prospective or lost profits of Buyer.

This warranty is effective on Middleby Marshall equipment sold on, or after, February 15, 1995.

MIDDLEBY MARSHALL INC.
OVEN LIMITED WARRANTY
(Non U.S.A.)

The Seller warrants equipment manufactured by it to be free from defects in material and workmanship for which it is responsible. The Seller's obligation under this warranty shall be limited to replacing or repairing, at Seller's option, without charge, F.O.B. Seller's factory, any part found to be defective and any labor and material expense incurred by Seller in repairing or replacing such part. Such warranty is limited to a period of one year from date of original installation or 15 months from date of shipment from Seller's factory, whichever is earlier, provided that terms of payment have been fully met. All labor shall be performed during regular working hours. Overtime premium will be charged to the Buyer.

This warranty is not valid unless equipment is installed, started, and demonstrated under the supervision of a factory-authorized installer.

Normal maintenance functions, including lubrication, adjustment of airflow, thermostats, door mechanisms, microswitches, burners and pilot burners, and replacement of light bulbs, fuses and indicating lights, are not covered by warranty.

Any repairs or replacements of defective parts shall be performed by Seller's authorized service personnel. Seller shall not be responsible for any costs incurred if the work is performed by other than Seller's authorized service personnel.

When returning any part under warranty, the part must be intact and complete, without evidence of misuse or abuse, freight prepaid.

Seller shall not be liable for consequential damages of any kind which occur during the course of installation of equipment, or which result from the use or misuse by Buyer, its employees or others of the equipment supplied hereunder, and Buyer's sole and exclusive remedy against Seller for any breach of the foregoing warranty or otherwise shall be for the repair or replacement of the equipment or parts thereof affected by such breach.

The foregoing warranty shall be valid and binding upon Seller if and only if Buyer loads, operates and maintains the equipment supplied hereunder in accordance with the instruction manual provided to Buyer. Seller does not guarantee the process of manufacture by Buyer or the quality of product to be produced by the equipment supplied hereunder and Seller shall not be liable for any prospective or lost profits of Buyer.

THE FOREGOING WARRANTY IS EXCLUSIVE AND IN LIEU OF ALL OTHER EXPRESS AND IMPLIED WARRANTIES WHATSOEVER. SPECIFICALLY THERE ARE NO IMPLIED WARRANTIES OF MERCHANTABILITY OR OF FITNESS FOR A PARTICULAR PURPOSE.

The foregoing shall be Seller's sole and exclusive obligation and Buyer's sole and exclusive remedy for any action, whether in breach of contract or negligence. In no event shall seller be liable for a sum in excess of the purchase price of the item.

TABLE OF CONTENTS

	Page
SECTION 1	
I. MODEL IDENTIFICATION	1
SERIES PS520 ELECTRICAL SPECIFICATIONS	2
II. COMPONENT FUNCTION	4
A. Conveyor Motor and Conveyor Belt	4
B. Blower Fan	4
C. Electric Heaters	4
D. Cooling Fan	4
E. Air Fingers and Blank Plates - See Figure 1-9	4
SECTION 2	
I. UNLOADING	7
PS520 OVEN INSTALLATION	
REQUIRED KITS AND EQUIPMENT	8
PARTS LIST FOR SERIES PS520 ELECTRIC OVEN	
INSTALLATION KIT	8
UTILITY ROUGH-IN DIMENSIONS AND POSITIONING	
FOR PS520-SERIES OVENS	12
CIRCUIT BREAKER	12
ELECTRICAL SPECIFICATIONS	12
ELECTRICAL RATING	12
SUPPLY WIRE	12
SUGGESTED	12
II. VENTILATION GUIDELINES	12
III. ELECTRICAL CONNECTION INFORMATION FOR	
PS520-SERIES OVENS.	13
IV. ELECTRIC SUPPLY FOR ELECTRIC-HEATED	
OVENS	12
SECTION 3 INSTALLATION	
I. CONTROL FUNCTIONS	15
II. COMPONENT INFORMATION AND LOCATION	16
A. Door Safety Switch	16
B. Blower Switch	16
C. Heat Switch	16
D. Temperature Controller	16
E. Conveyor	17
MEASURING CONVEYOR SPEED.	17
III. STEP-BY-STEP OPERATION	18
A. Startup Procedures	18
Daily Startup	18
Power Failure	18
B. Shutdown Procedure	18

**TABLE OF CONTENTS
(Continued)**

	Page
IV. NORMAL OPERATION - STEP-BY-STEP	20
A. Daily Startup Procedure	20
B. Daily Shutdown Procedure	20
V. QUICK REFERENCE: TROUBLESHOOTING	22
SECTION 4 MAINTENANCE	
I. MAINTENANCE - DAILY	24
A. Exterior	24
B. Cooling Fan	24
C. Conveyor Belt	24
D. Crumb Pans	24
II. MAINTENANCE - MONTHLY	25
A. Removing Conveyor From Oven For Cleaning	25
B. Air Fingers Disassembly For Cleaning	27
C. Reassembly of Air Fingers	28
D. Reinstall End Plugs	31
E. Conveyor Reassembly Into Oven	32
F. Checking Conveyor Belt Tension	32
G. Conveyor Belt Link Removal	33
H. Attaching Drive Chain	34
III. MAINTENANCE - EVERY 3 MONTHS	35
A. Electrical Terminals	35
B. Ventilation	35
IV. MAINTENANCE - EVERY 6 MONTHS	35
PS520-SERIES ELECTRIC OVEN KEY SPARE	
PARTS	36
KEY SPARE PARTS KIT	36
SECTION 5 TROUBLESHOOTING	
Troubleshooting Charts	37
SECTION 6 - PARTS LIST	
SINGLE OVEN EXPLODED VIEW	41
RELAY PANEL	43
BLOWER ASSEMBLY	45
CONTROL PANEL	47
SINGLE CONVEYOR	49
SECTION 7 ELECTRICAL SCHEMATICS	
Wiring Diagram, E208-240V 50/60/1, PS520	51
Wiring Diagram, E380-480V 50/60/1, PS520	52
Wiring Diagram, E230-240V CE PS520/1820S	53
Wiring Diagram, E380-400V CE PS520/1820S	54

NOTE

Wiring Diagrams are in Section 7 of this Manual.
The diagram for each oven is also on the lower
inner surface of its Control Console.

SECTION 1 DESCRIPTION

I. MODEL IDENTIFICATION

The Middleby Marshall PS520-Series may be used either as a single oven or stacked for use as double or triple ovens.

A single PS520-Series Oven (Figure 1-1) is mounted on a base pad with legs. A double oven (Figure 1-2) consists of two, *stacked*, single ovens. A triple oven (Figure 1-3) consists of three stacked single ovens. The lower oven is mounted on a base pad.

On a double or triple oven, the ovens operate independently. All ovens use identical controls and components. One oven can be cleaned or serviced, while the others are operating.

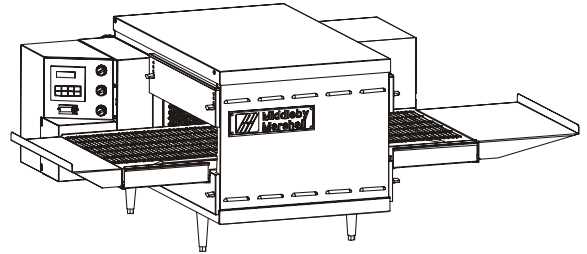

Figure 1-1. Single PS520 Oven

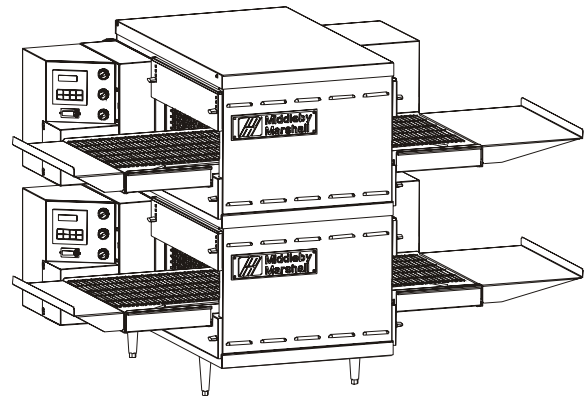

Figure 1-2. Double PS520 Oven

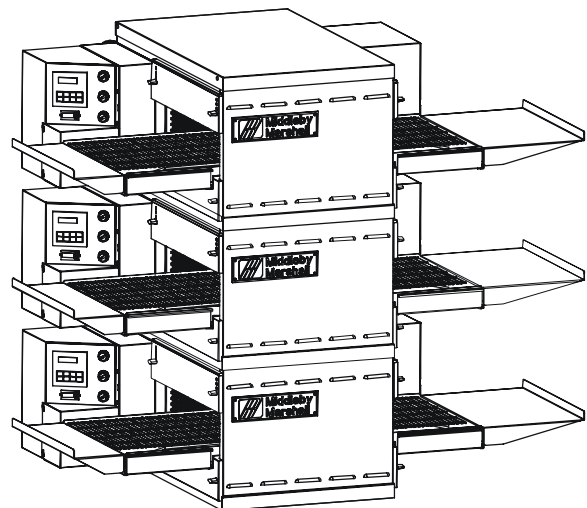

Figure 1-3. Triple PS520 Oven

**SECTION 1
DESCRIPTION**

PS520 SERIES OVEN SPECIFICATIONS

Conveyor Belt Width	18.00" (457mm)
Heating Zone Length	20.00" (5098mm)
Baking Area Square Feet	2.5 sq. ft. (0.23 sq. m.)
Overall Dimension Standard Single Oven w/Legs	42.00" (1067mm) L x 35.21" (894mm) W x 21.72" (786mm) H x
Overall Dimension Double Oven	42.00" (1067mm) L x 35.21" (894mm) W x 37.27" (947mm) H x
Overall Dimension Triple Oven	42.00" (1067mm) L x 35.21" (894mm) W x 52.82" (1342mm) H x
Weight of Single Oven	250 lb (93.3kg)
Shipping Weight	325 lb (121.3kg)
Shipping Cube	22.1 ft ³ (0.62 m ³)
Operating Range	8.3 kW/hr
Maximum Operating Temperature	550°F (287°C)
Warm-up Time	20 min.
Belt Speed Limits	1-10 minutes

SERIES PS520 ELECTRICAL SPECIFICATIONS

Main Blower & Elements Voltage	Control Circuit Voltage	Phase	Frequency	Amperage Draw	Poles	Wires
208-240V (ETL Listed)	208-240V	1 Ph	50/60 Hz	39.9 Amp	2 Pole	3 Wire (2 hot, 1 grd)
HEATER AMPERAGE						
		Voltage	kW	Amp		
		208	8.3	39.9		
		230	7.6	33.0		
		240	8.3	34.6		
380V Export (CE Listed) (Non-CE Version)	208-240V	1 Ph	50/60 Hz	21.8 Amp	3 Pole	4 Wire (2 hot, 1neut, 1 grd)
HEATER AMPERAGE						
		Voltage	kW	Amp		
		380	8.3	21.8		
		400	9.2	23.0		
480V (ETL Listed)	208-240V	1 Ph	50/60 Hz	17.3 Amp	3 Pole	4 Wire (2 hot, 1neut, 1 grd)
HEATER AMPERAGE						
		Voltage	kW	Amp		
		480	8.3	17.3		

NOTE

Wiring Diagrams are contained in Section 7 of this Manual and are also located inside the oven at the bottom of the Control Panel

This Manual Must Be Kept For Future Reference

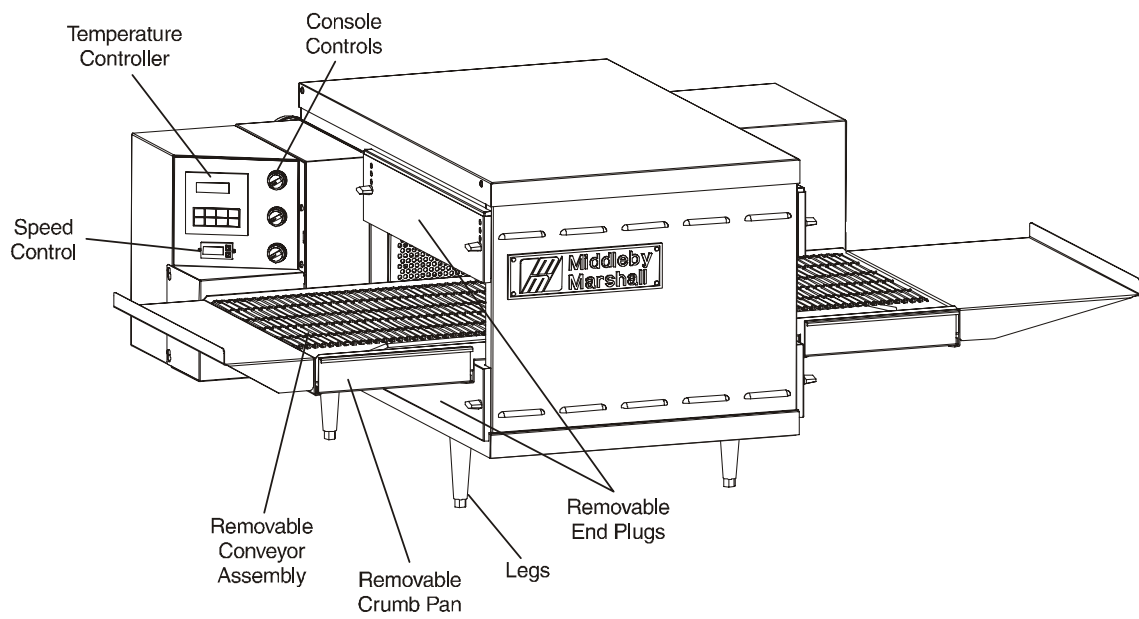

Figure 1-4. PS520-Series Oven Components Locations

SECTION 1 DESCRIPTION

II. COMPONENT FUNCTION (Figure 1-4)

II. COMPONENT FUNCTION

A. Conveyor Motor and Conveyor Belt

The conveyor belt is driven by a variable-speed electric motor (Figure 1-5) operating through a gear reducer. The motor speed is controlled by a digital control. The stainless-steel wire belt can travel in either direction at variable rates ranging from 3 minutes to 30 minutes; this is the time that a product can take to pass through the oven.

B. Blower Fan

The blower fans are located at the rear of the oven. These blowers force heated air through the air fingers. The BLOWER switch must be set to "ON" or "I" for oven warmup and baking.

C. Electric Heaters

There is one heater element mounted on the inside of the rear panel. The element is connected to an electrical control which is energized by the temperature controller.

D. Cooling Fan — See Figure 1-5 and Figure 1-6

The cooling fan is located in the back of the oven. The cooling fan draws air through its grille, blowing it through the blower motor compartment and the control compartments into the oven top and exhausted out the front louvers.

E. Air Fingers and Blank Plates - See Figure 1-7

E1. Air Fingers

An Air Finger Assembly is made up of three parts:

1. **Outer Plate** - The Outer Plate is the removable covering with tapered holes, which direct the air stream onto the product being baked.
2. **Inner Plate** - The perforated Inner Plate is vital in forming the unique air jets. It must be assembled into the manifold with its holes aligned with the holes of the outer plate.
3. **Manifold** - The Manifold is the assembly which slides on tracks into the oven plenum.

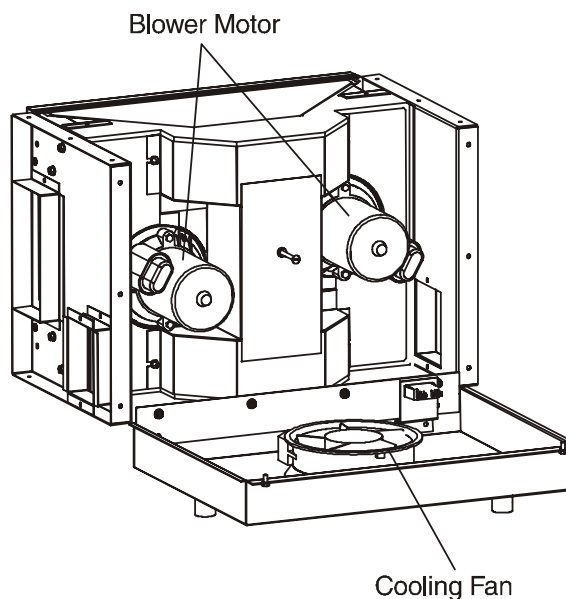

Blower Assembly

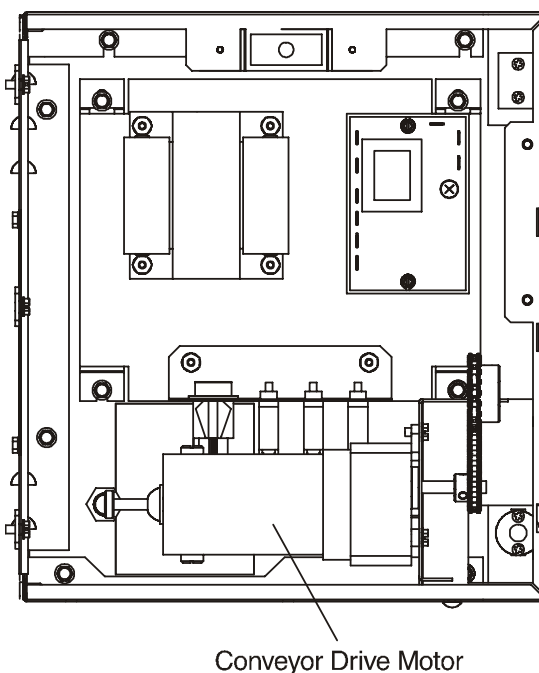

Right Control Box

Figure 1-5. Machinery Compartment Components

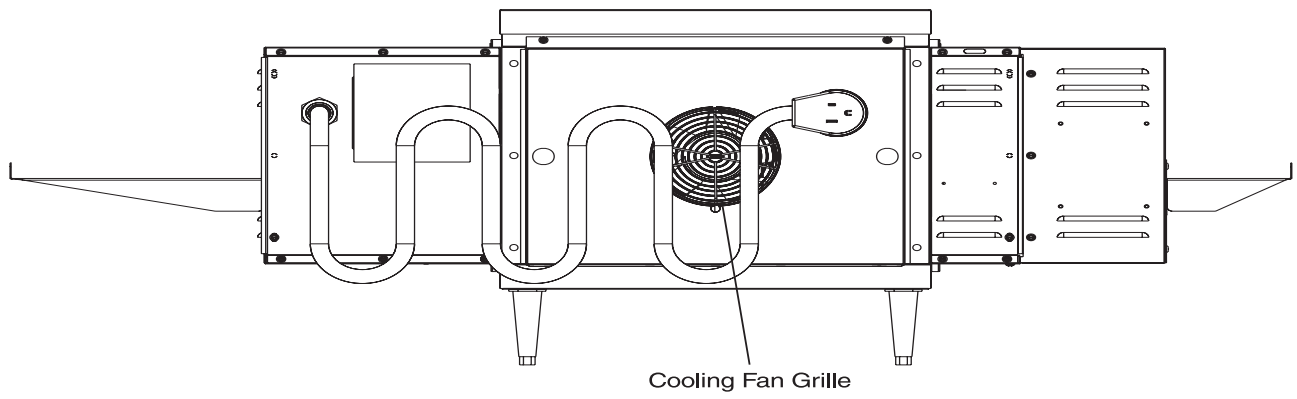

Figure 1-6. Cooling Fan

SECTION 1
DESCRIPTION

F2. Blank Plates

1. **Blank Plates-** The Blank Plates are available to install on the plenum where an air finger is not required.

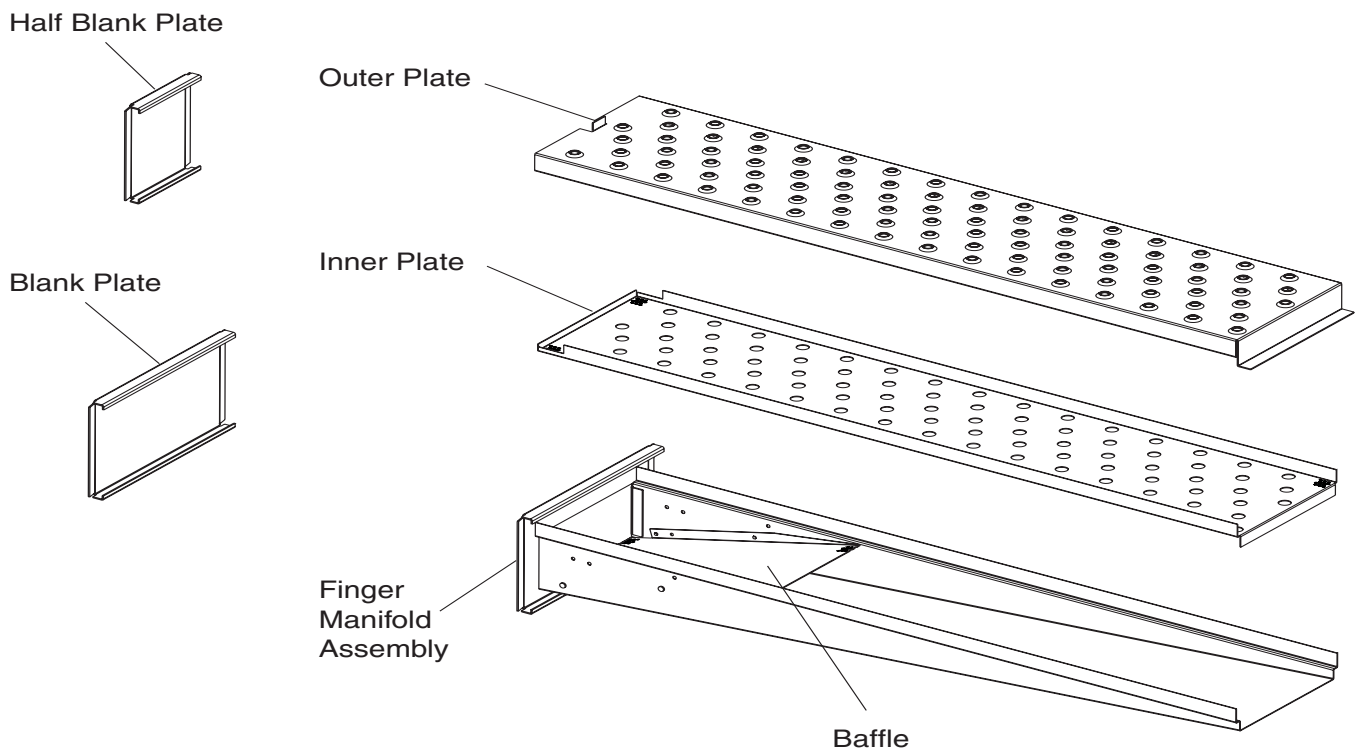

Figure 1-7. Blank Plates (two sizes) and an Air Finger.

SECTION 2 INSTALLATION

NOTE: *The oven, when installed, must be electrically grounded in accordance with local codes, or in the absence of local codes, with the National Electrical Code (NEC), or ANSI/NFPA70.*

NOTE

There must be adequate clearance between the oven and any adjacent combustible construction. Clearance must also be provided for servicing and for operation.

CAUTION

It is recommended that the oven be placed under a ventilation hood for adequate air supply and ventilation.

CAUTION

Do not obstruct the flow of ventilation air to and from your oven. Do not obstruct the fan holes in the rear of the unit.

CAUTION

On ovens with the Machinery Drive Compartment located at the right end, a minimum clearance of 0" to a left side wall, 18" to a right side wall and 6" from a back wall to air openings at the rear of the oven must be maintained.

For servicing and cleaning, a minimum of 18" clearance from all walls is recommended.

I. UNLOADING

Your Middleby Marshall PS520-Series Oven is shipped partially assembled. It will arrive in a carton on a crate.

Carton size for a PS520-Series Oven is:

44-1/4" (1124mm) Long ×

37-1/2" (953mm) Wide ×

23" (584mm) High ×

The crate and carton must be examined before signing the Bill of Lading. Report any visible damage to the transport company, and check for the proper number of crates. If apparent damage is found, make arrangements to file a claim against the carrier. Surface Interstate Commerce Regulations (U.S.A.) require that the claim must be initiated by the consignee within 10 days from the date that the shipment is received.

SECTION 2
INSTALLATION

**PARTS LIST FOR SERIES PS520 ELECTRIC OVEN
INSTALLATION KIT
Single and Double Stack Ovens
P/N 48397**

ITEM NO.	QTY	PART NO.	DESCRIPTION
1	4	3101908	LEG 4" AD FT
2	2	48392	INSULATION BOTTOM TRAY
3	1	48394	BOTTOM TRAY WELDMENT
4	1	48396	TOP COVER
5	4	51387	SCREW MSSLT THREAD 8-32 x 1/2, 18-8
6	1	52358	OWNER'S OPERATING & INSTALLATION MANUAL

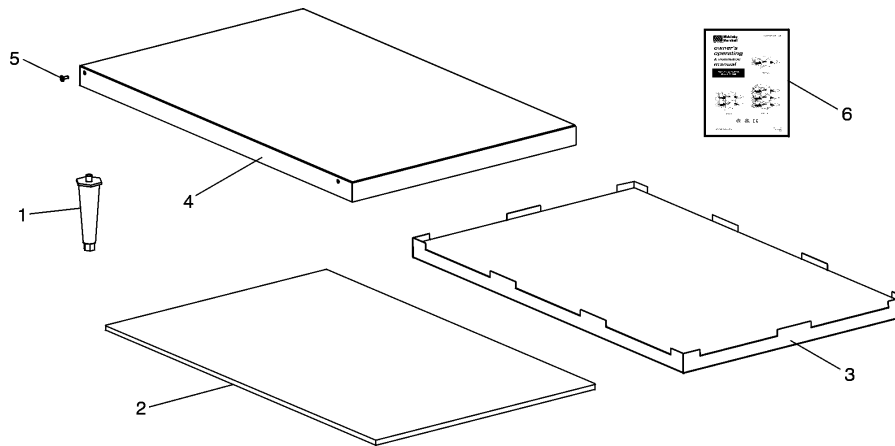

**PARTS LIST FOR SERIES PS520 ELECTRIC OVEN
INSTALLATION KIT
Triple Stack Oven
P/N 54593**

ITEM NO.	QTY	PART NO.	DESCRIPTION
1	2	48392	INSULATION BOTTOM TRAY
2	1	48394	BOTTOM TRAY WELDMENT
3	1	48396	TOP COVER
4	4	51387	SCREW MSSLT THREAD 8-32 x 1/2, 18-8
5	4	M3828	PIN, ALIGNMENT
6	1	52358	OWNER'S OPERATING & INSTALLATION MANUAL

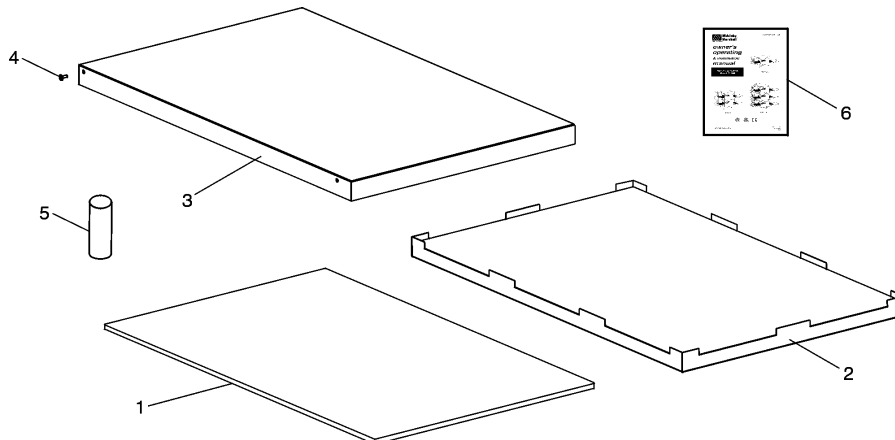
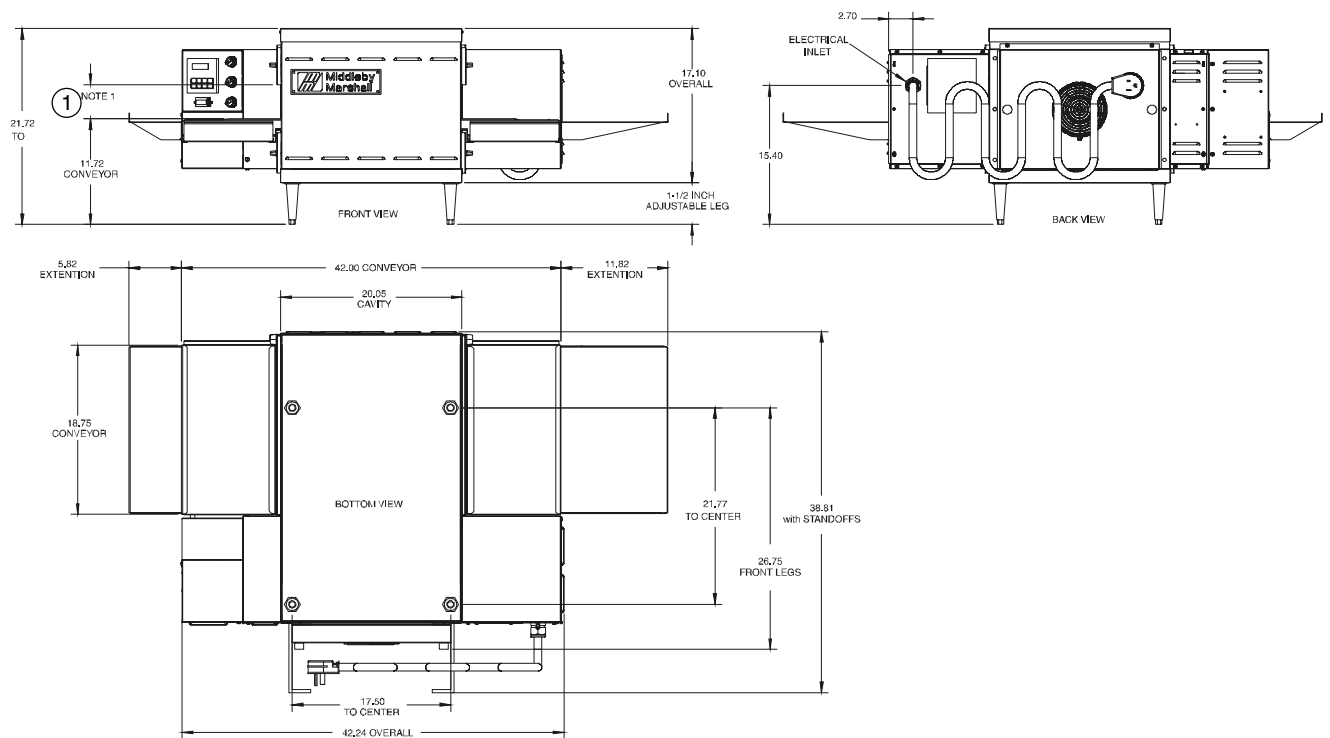

Figure 2-1. PS520-Series Electric Oven Installation Parts

Figure 2-5. MODEL PS520 SINGLE OVEN DIMENSIONS



① The Opening Height is Adjustable from 2-1/4 inch minimum to 3-3/4 inch maximum in 1/2 inch increments.

SECTION 2
INSTALLATION

Figure 2-6. MODEL PS520 DOUBLE OVEN DIMENSIONS

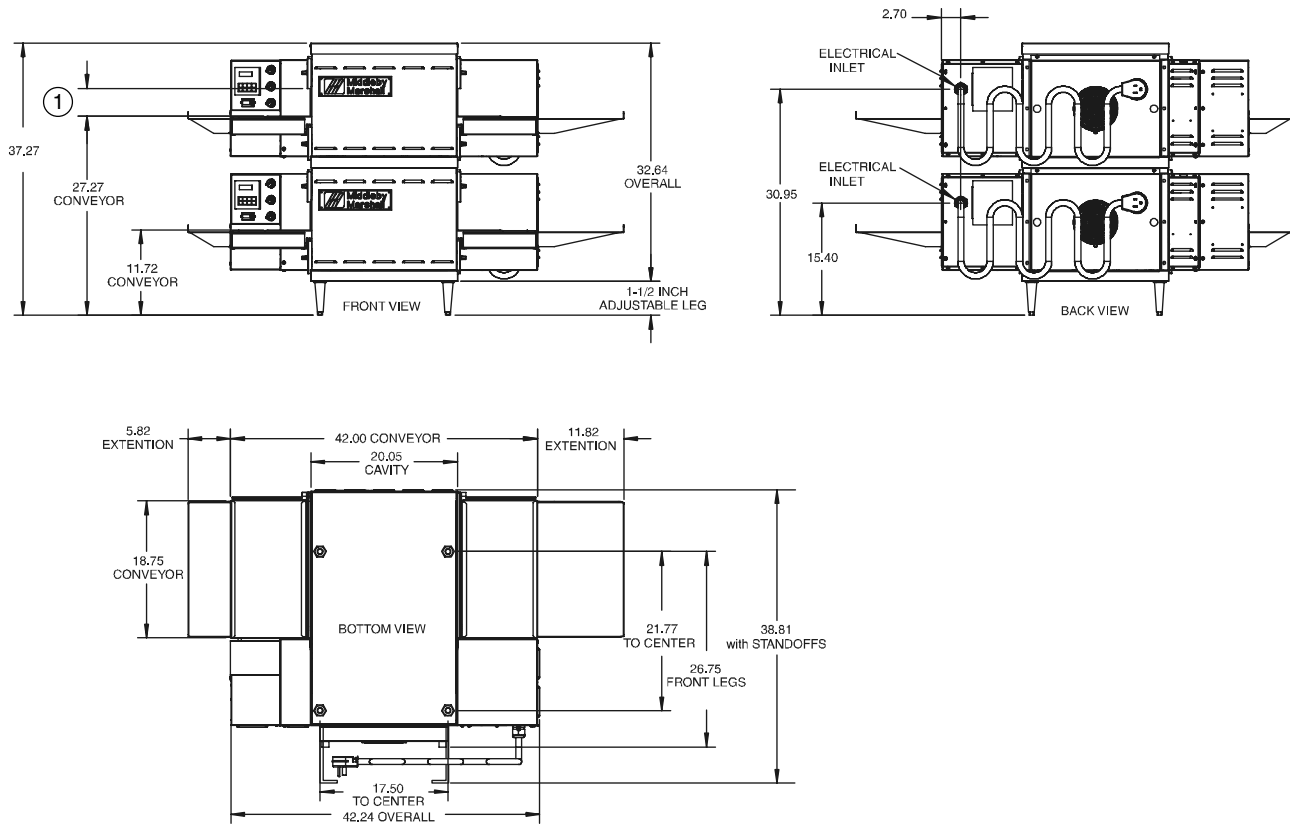

① The Opening Height is Adjustable from 2-1/4 inch minimum to 3-3/4 inch maximum in 1/2 inch increments.

Figure 2-7. MODEL 520 TRIPLE OVEN DIMENSIONS

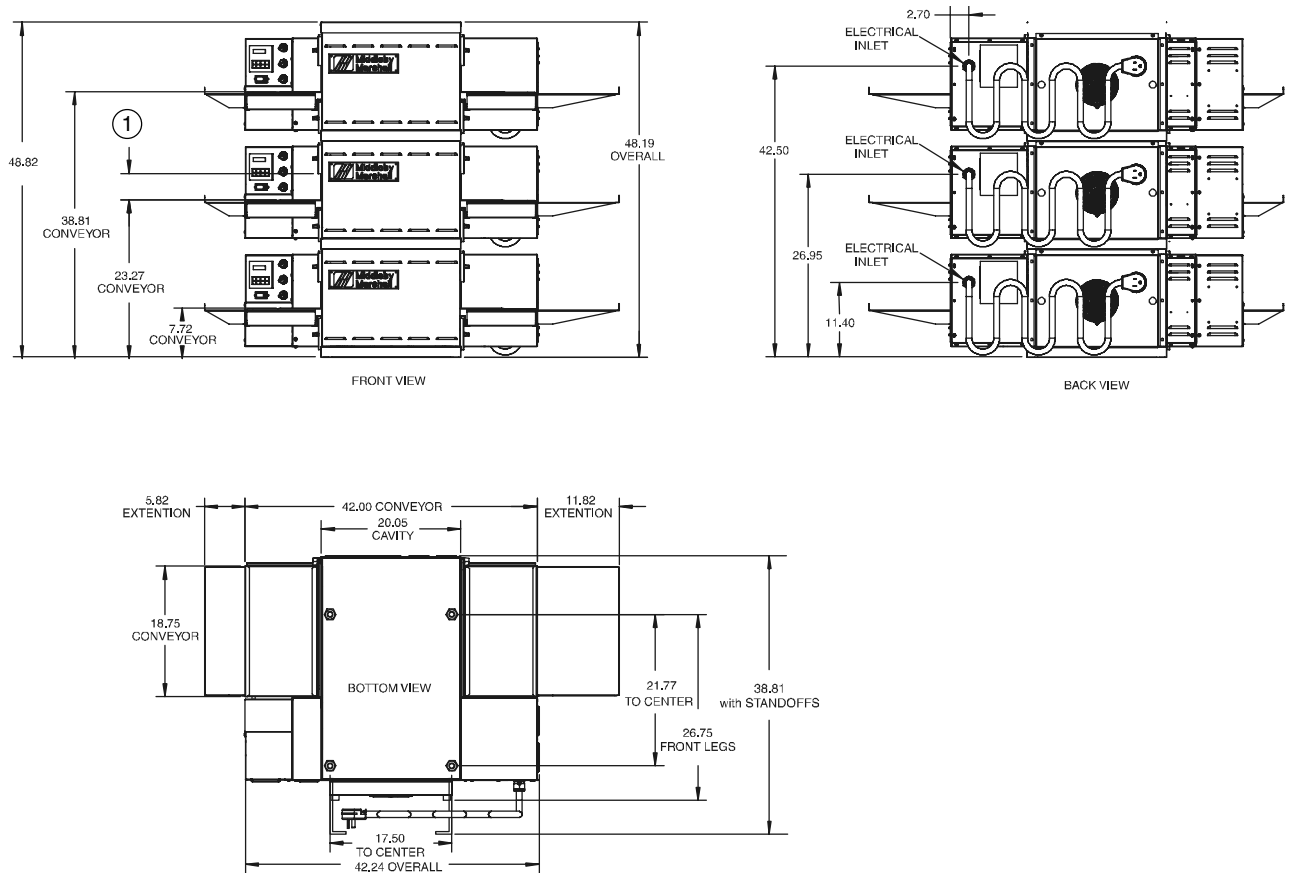

① The Opening Height is Adjustable from 2-1/4 inch minimum to 3-3/4 inch maximum in 1/2 inch increments.

SECTION 2
 INSTALLATION **UTILITY ROUGH-IN DIMENSIONS AND POSITIONING
 FOR PS520-SERIES OVENS**

WARNING
**DO NOT USE CONDUIT OR GAS LINE
 FOR GROUND CONNECTION.**

CAUTION
**IT IS RECOMMENDED THAT THE OVEN
 BE PLACED UNDER A VENTILATION
 HOOD FOR ADEQUATE AIR SUPPLY
 AND VENTILATION.**

**ELECTRIC SUPPLY TO BE
 PROVIDED BY CUSTOMER**

CIRCUIT BREAKER

Separate circuit breaker with lockout/tagout electrical shutoff for each oven. Wire each oven separately.

50 Amp circuit breaker for 208-240V, or 30 Amp circuit breaker for 380-480V.

ELECTRICAL SPECIFICATIONS

DOMESTIC: 208V main blower motors and elements, 1 Ph, 39.9 Amp draw, 50/60 Hz, 208-240V control circuit, 2 pole, 3 wire system per oven (2 hot, 1 grd).

Do NOT use conduit for ground.

or

DOMESTIC: 240V main blower motors and elements, 1 Ph, 34.6 Amp draw, 50/60 Hz, 208-240V control circuit, 2 pole, 3 wire system per oven (2 hot, 1 grd).

230V main blower motors and elements, 1 Ph, 33.0 Amp draw, 50/60 Hz, 208-240V control circuit, 2 pole, 3 wire system per oven (2 hot, 1 grd).

Do NOT use conduit for ground.

or

EXPORT: 380V elements, 1 Ph, 23.0 Amp draw, 50/60 Hz, 208-240V control circuit and main blower motor, 4 pole, 4 wire system per oven (2 hot, 1 neutral, 1 grd).

400V elements, 1 Ph, 21.8 Amp draw, 50/60 Hz, 208-240V control circuit and main blower motor, 4 pole, 4 wire system per oven (2 hot, 1 neutral, 1 grd).

Do NOT use conduit for ground.

or

EXPORT: 480V elements, 1 Ph, 17.3 Amp draw, 50/60 Hz, 208-240V control circuit and main blower motor, 2 pole, 4 wire system per oven (2 hot, 1 neutral, 1 grd).

Do NOT use conduit for ground.

ELECTRICAL RATING

7.6 – 9.2 kW/hr.

SUPPLY WIRE

Supply wire size must be in accordance with the National Electrical Code (current edition) and must be in compliance with local codes.

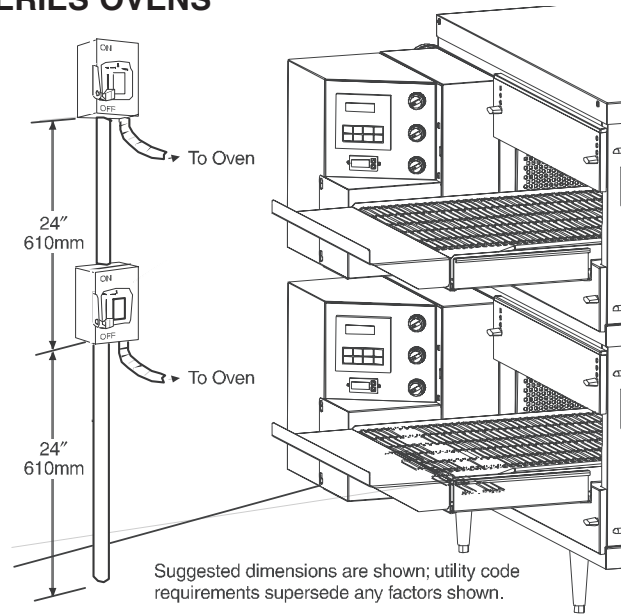

**Figure 2-9. Typical PS520-Series Oven(s)
 Installation**

GROUNDING CONNECTION

There is an equipotentiality ground located near the incoming terminal block.



This is for an external equipotentiality ground cable.

BASIC STEPS

1. Remove outer-most M6 Nut & Flat Wash
2. Install Equipotential Ground Wire with ri terminal onto M6x20mm screw.
3. Reinstall FlatWasher & M6 N
4. Tighten secure

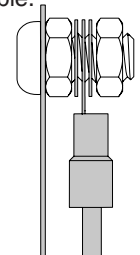

SUGGESTED

If space permits, service should be located near the control console end of the oven(s) to allow convenient access to safety switches.

CAUTION
**UNIT MUST HAVE AIR VENT PLATES IN-
 STALLED OR WARRANTY WILL BE VOID.**

II. VENTILATION GUIDELINES

A mechanically driven ventilation system is recommended for the PS520 Series Middleby Marshall conveyORIZED electric ovens.

Local codes and conditions vary greatly from one area to another and must be complied with. Following are the suggested requirements for good ventilation. Please remember these are recommendations or guidelines, you may have a special condition or problem that will require the services of a ventilation engineer or specialist. Proper ventilation is the oven owner's responsibility. Improper ventilation can inhibit oven performance.

Please Note: There are now two "stand off" 'C' Channels that must be installed in the field (See **Section 6: PARTS LIST**, page 44-45 for reference, Item 5).

These 'C' Channel brackets are installed in the vertical plane using existing screws (Item 6) to support these 'C' Channels using the upper and lower Key Hole openings in the 'C' Channels. The 'C' Channels are identical and once installed will allow ample amounts of air through the cooling fan mounted on the rear side of the oven by keeping the oven away from the rear wall.

If you have any questions about how to mount these two 'C' Channel brackets, kindly phone **Middleby Technical Services at 847-741-3300. Press 3, then 5 for Technical Support.**

III. ELECTRICAL CONNECTION INFORMATION FOR PS520-SERIES OVENS.

WARNING

Authorized supplier personnel normally accomplish the connections for the ventilation system, electric supply, as arranged by the customer. Following these connections, the factory-authorized installer can perform the initial startup of the oven.

Check the oven data plate (Figure 2-10) before making any electric supply connections. Electric supply connections must agree with data on the oven data plate.

NOTE: The electric supply installation must satisfy the requirements of the appropriate statutory authority, such as the National Electrical Code (NEC), ANSI/NFPA70, (U.S.A.); the Canadian Electrical Code, CSA C22.2; the Australian Code AG601; or other applicable regulations.



MODEL NO. SERIAL NO.

ID NO.

VAC kW HZ

AMPS PHASE WIRE SERVICE

MOTOR VOLTS AMPS

ADDITIONAL LOAD VOLTS AMPS

TOTAL LOAD VOLTS AMPS

(PS5XX)
DO NOT INSTALL CLOSER THAN INCHES TO A NON-COMBUSTIBLE BACK WALL, AND INCHES TO NON-COMBUSTIBLE SIDE WALLS ONLY. (PS2XX) FOR INSTALLATION ON COMBUSTIBLE FLOORS ADJACENT TO COMBUSTIBLE WALLS WITH THE FOLLOWING MINIMUM CLEARANCES:
 INCHES RIGHT SIDE WALL, INCHES TO LEFT SIDE WALL
 INCHES TO BACK WALL,
N'INSTALLEZ PAS Á MOINS DE PO D'UN PANNEAU ARRIÈRE INCOMBUSTIBLE ET Á PO DE PANNEAUX LATÉRAUX INCOMBUSTIBLES UNIQUEMENT.
DESTINÉ A UN USAGE AUTRE QUE DOMESTIQUE.
INTENDED FOR OTHER THAN HOUSEHOLD USE.

ELGIN, ILLINOIS, 60120, U.S.A. 44957 REV D

Figure 2-10. Typical Electric Oven Data Plate

A fused disconnect switch or a main circuit breaker (customer furnished) **MUST** be installed in the electric supply line for each oven; it is recommended that this switch/ circuit breaker have lockout/tagout capability. The electric supply connection must meet all national and local electrical code requirements. Copper is the recommended material for the electrical supply conductors.

IV. ELECTRIC SUPPLY FOR ELECTRICALLY HEATED OVENS

Power requirements for electrically heated ovens are usually 208 - 240VAC, 1-phase, 3-wire (2 'hot', 1 ground), although ovens built for export can have power requirements of 380VAC and 480VAC. (These ovens have a 4-wire system.) A 1.5" (38mm) diameter cutout/hole in the back of the machiney compartment provides access for the electrical supply connections on 380V and 480V units. 208V and 240V units have a cord and plug. Using flexible cable(s) for the electrical power supply conductors requires a 2" (51mm) strain-relief fitting (not furnished) to enable safe access to the terminal block from which oven power is distributed.

The supply conductors must be of the size and material (copper) recommended to provide the current required; (refer to the data plate for the ampere specifications). The electric current rating for each conductor supplying a PS520-Series Oven ranges from a minimum of 17.3 amperes to a maximum of 39.9 amperes.

Typical specifications for each PS520-Series Oven are 208V or 240V, 1-phase, 3-wire, 8.3kW; this oven requires 50-ampere service. A PS520-Series Double Oven (Figure 1-2) installation would require two 50-ampere service connections, one for each oven; the 8.3kW power consumption also doubles for such an installation to 16.6kW.

The 208V or 240VAC electrically heated oven uses two legs of the supplied power to provide 208V or 240VAC power for the oven control circuitry.

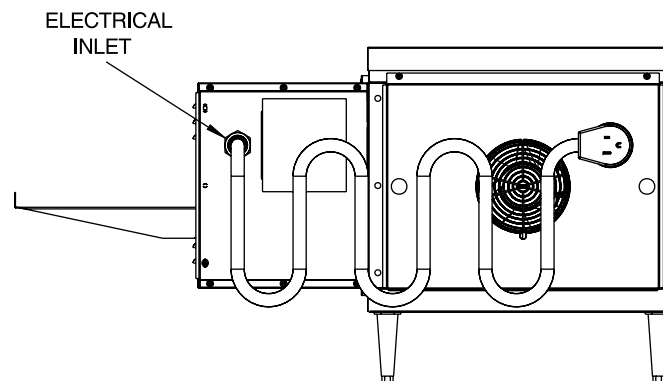

Figure 2-11. Junction Connection Box

NOTES

SECTION 3 OPERATION

I. CONTROL FUNCTIONS

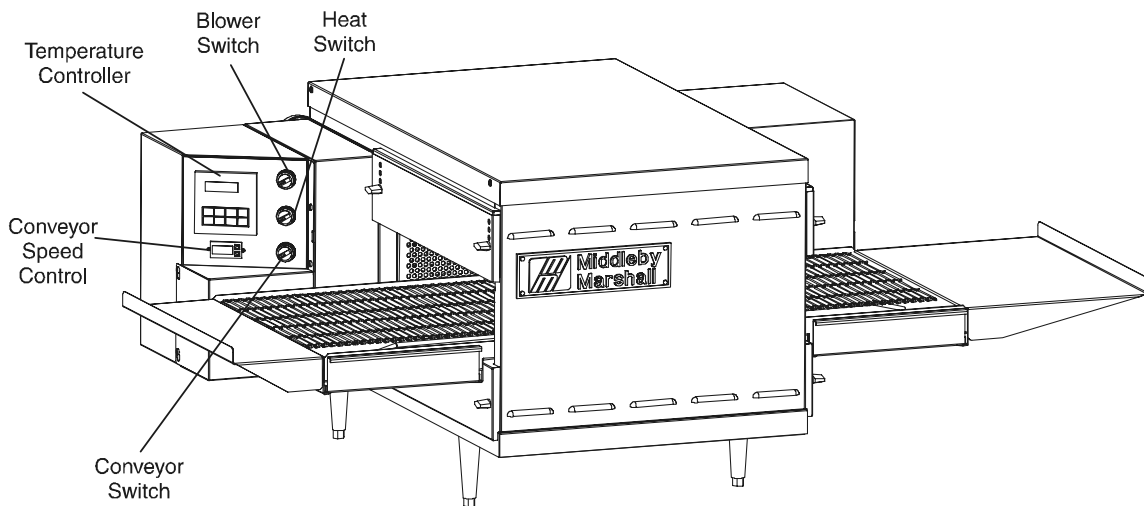

Figure 3-1. PS520-Series Oven Control Functions

WARNING

A possibility of injury from rotating parts and electric shock exists in this oven. Never disassemble or clean the oven with the BLOWER switch or any other oven control turned "ON" or "I". Turn "OFF" or "O" and lockout or tagout all electric power to the oven before attempting to clean or service this oven.

SECTION 3 OPERATION

II. COMPONENT INFORMATION AND LOCATION (Figures 3-1 and 3-2)

A. Door Safety Switch

The Door Safety Switch is located at the lower right side of control panel opening. Opening the control panel door permits this switch to open, disconnecting power to all electrical controls.

CAUTION

Do NOT touch the wires going to this safety switch. Current is always present.

B. Blower Switch

The blower switch has two positions. The switch must be "ON" or "I" for the main blowers to come on and permit the oven to run. The fan circulates the air throughout the oven and must stay on during baking and during the cool down cycle above 200°F (93°C) to prevent blower bearing damage. To protect the blower motor and bearings a thermostatic override is built into the oven.

If the temperature inside the oven is over 180°F (82°C) the main blower will continue to run after the blower switch is turned to the "OFF" or "O" position.

C. Heat Switch

Turning the HEAT switch to "ON" or "I" will energize the electric heating system. This switch is in series with the blower fan motor and high temperature override switch. Both switches must be closed before the heating elements can be energized.

D. Temperature Controller

The temperature controller is a solid-state, PID type to maintain the operator-set temperature. The temperature controller continuously monitors the oven temperature and turns on the modulating solid state relay controller. The heat is on for the time required to maintain a constant oven temperature.

The temperature controller contains a low-limit switch which allows the oven to cool down to 200°F (93°C) before shutting off the blower. A high-limit indication (ALM 1) will appear on the display if the oven reaches 650°F (343°C).

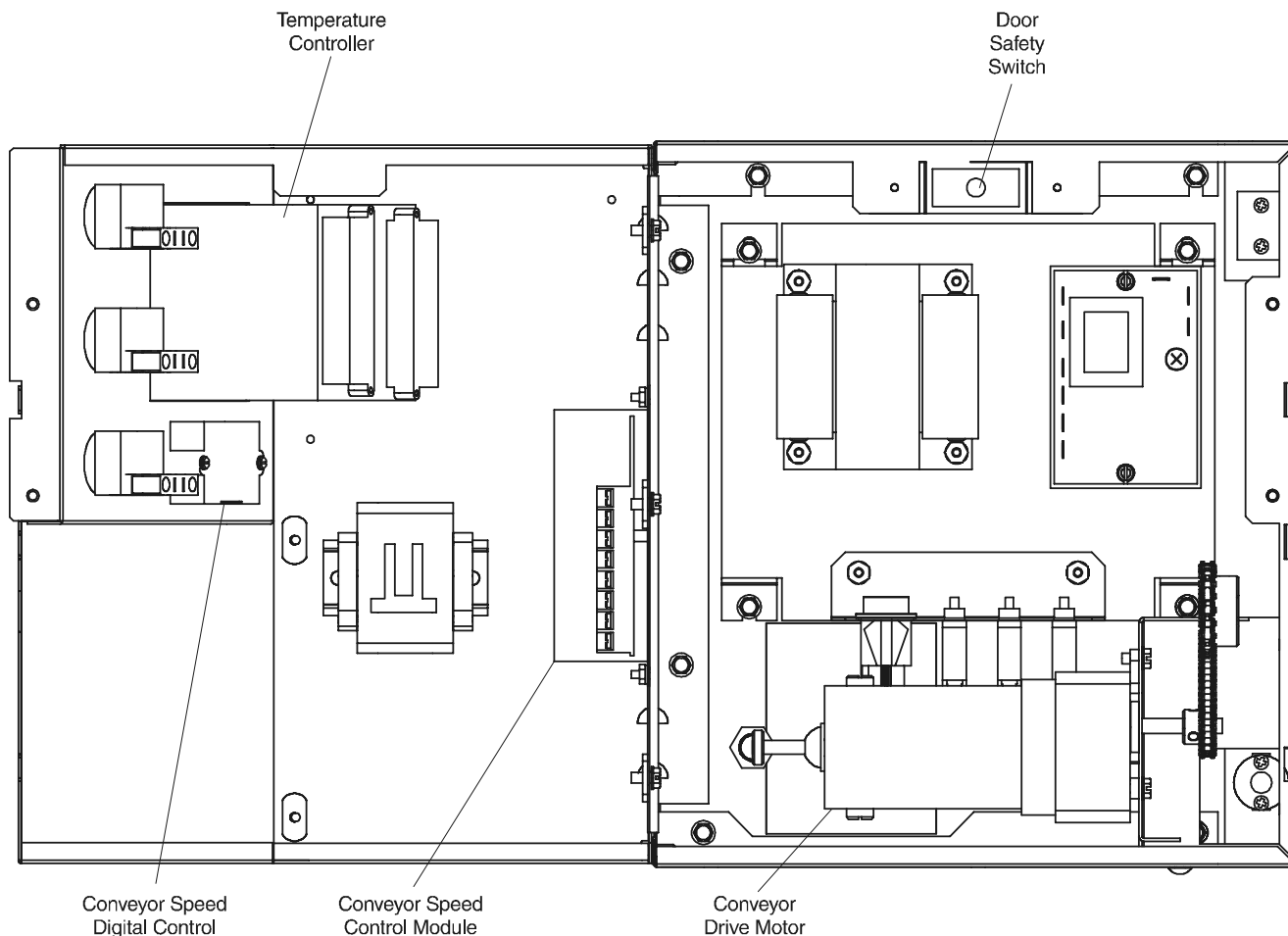

Figure 3-2. Interior View of Control Console

E. Conveyor

The on-off switch for the conveyor motor is on the control panel. Also on the control panel is the digital conveyor speed control. The digital control can be adjusted from 1-10 min. bake time (conveyor speed). Refer to Figure 3-3.

Conveyor speed is measured by the amount of time it takes for an item to go through the bake chamber of the oven.

MEASURING CONVEYOR SPEED.

See Figures 3-4 and 3-5.

To check conveyor speed, place a product item at the entrance end of baking chamber as shown. Time how long it takes for the leading edge of the item to go from the entrance end of the baking chamber to the exit end. This should be the conveyor speed shown on the conveyor speed digital control.

NOTE: In Figures 3-4 and 3-5, the oven shown is with the conveyor running right to left.

WARNING

Possibility of injury from rotating parts and electrical shock exist in this oven.

Never disassemble or clean the oven with the blower switch or any other part of the oven turned "ON" or "I". Turn "OFF" or "O" and lockout or tagout all electrical power to the oven before attempting to clean or service this oven.

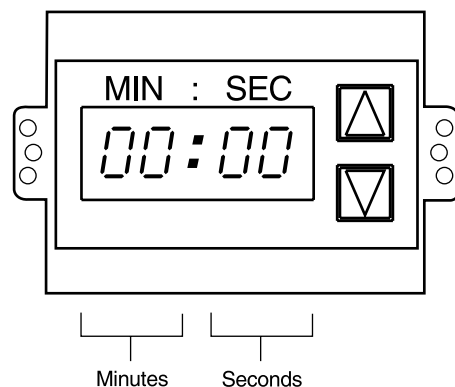

Figure 3-3. Conveyor Speed Digital Control

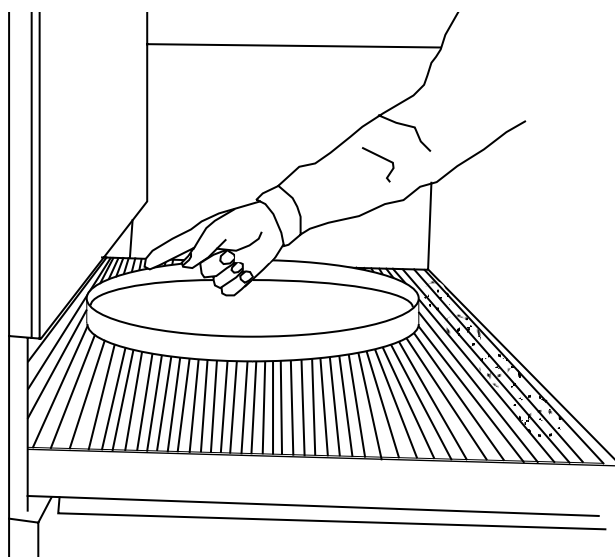

Figure 3-4. Product at entrance end of baking chamber – BEGINNING OF TIMING

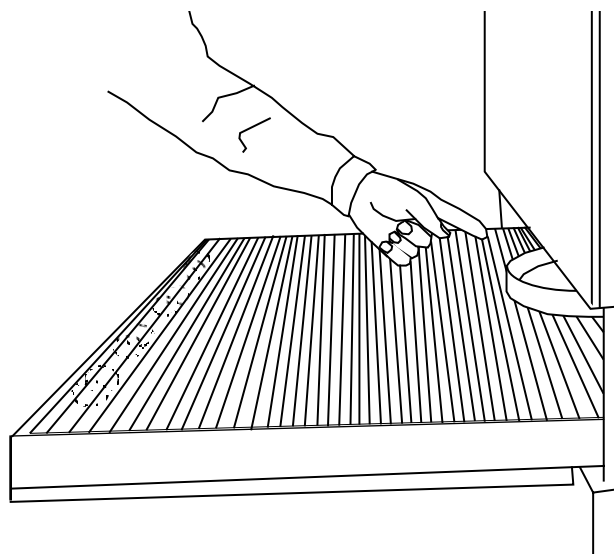

Figure 3-5. Product at exit end of baking chamber – END OF TIMING

SECTION 3 OPERATION

WARNING

**OVEN MUST BE KEPT CLEAR OF
COMBUSTIBLES AT ALL TIMES.**

III. STEP-BY-STEP OPERATION

A. Startup Procedures

Daily Startup

1. Turn the BLOWER switch (Figure 3-6) to the "ON" or "I" position. This starts the main blower fan and the cooling fans. The blower circulates air through the air fingers and must stay on during the cooking or baking process.

2. Check to see if the cooling fans (see Figure 1-8) are operating when the blower switch (see Figure 3-6) is turned "ON" or "I". The cooling fans cool the control components and blower motor. The cooling fans, located at the rear of the oven blows air into and through the cabinet. Air is exhausted through the front of the cabinet and also out the front of the oven. Refer to Daily Maintenance Section for fan intake checking procedure.

IMPORTANT NOTE

The cooling fan operates when the BLOWER switch is turned "ON" or "I". It must operate to keep the control console below 140°F (60°C).

3. Turn the CONVEYOR switch (Figure 3-6) to the "ON" or "I" position. This starts the conveyor belt moving through the oven. Set the conveyor speed for the desired baking time. Refer to the following Procedures E, F and G.

4. Set the temperature controller to the desired baking temperature.

NOTE: For complete temperature controller operation instructions refer to Step C.

5. Turn the HEAT switch (Figure 3-6) to the "ON" or "I" position. This completes a circuit to supply electric power to the electric heating system.

6. Oven will reach a baking temperature of 500°F (232°C) in approximately 20 minutes. Allow the oven to cycle for 30 minutes after it has reached desired bake temperature. The oven is now ready for baking.

Power Failure

In case of power failure, turn off all switches and remove product. After power has been reestablished follow normal startup procedure.

B. Shutdown Procedure

1. Turn the BLOWER and HEAT switches to "OFF" or "O".

NOTE: The blowers will remain on until the oven temperature cools down to 200°F (93°C) at which time they will stop automatically.

2. Make certain that there are no products left on the conveyor inside the oven. Turn the CONVEYOR switch to "OFF" or "O".

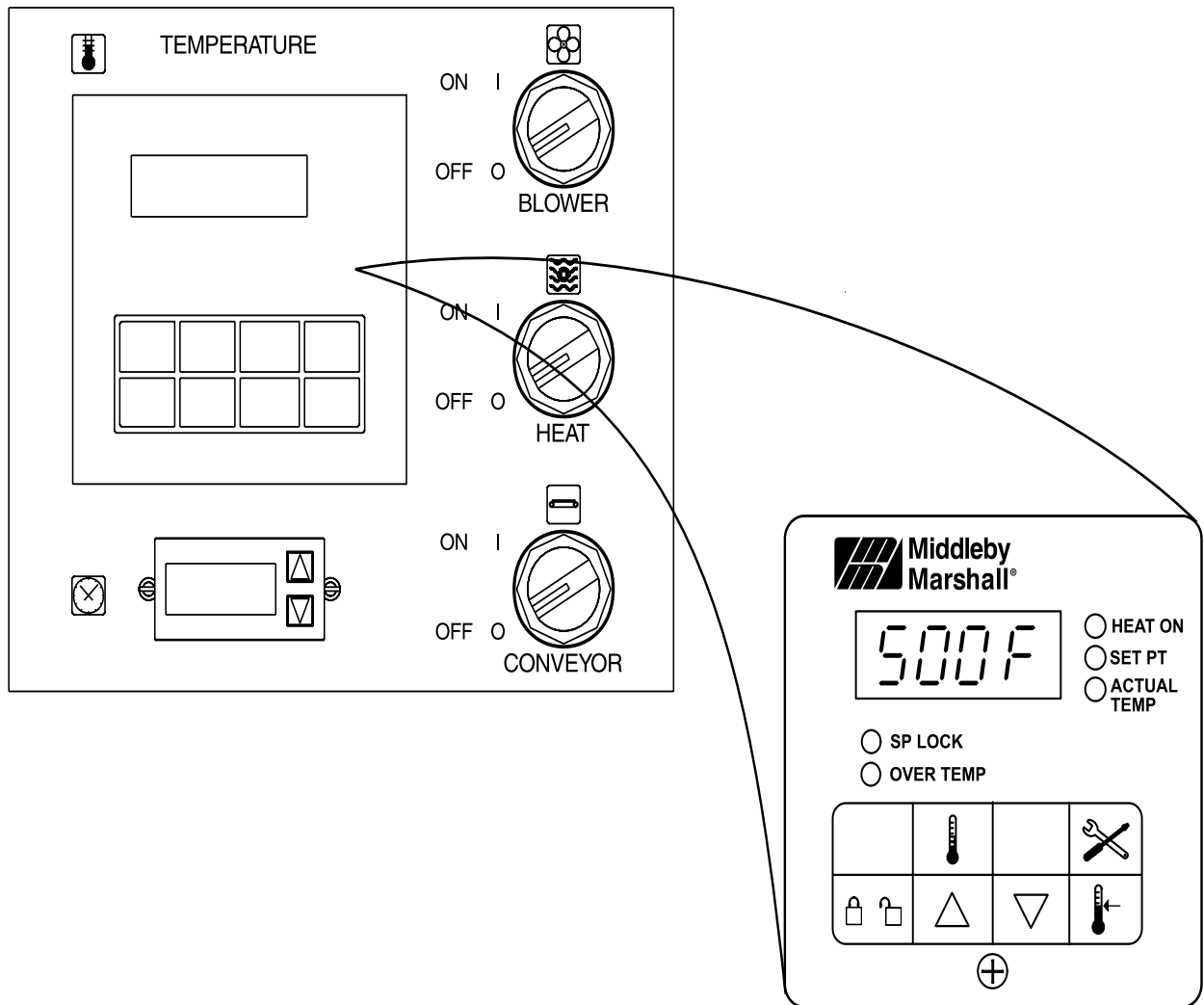

Figure 3-6. Control Panel

SECTION 3
OPERATION

IV. NORMAL OPERATION - STEP-BY-STEP

A. Daily Startup Procedure

1. Check that the circuit breaker/fused disconnect is in the on position.

2. Turn the "BLOWER" (☸) switch to the "ON" ("I") position.

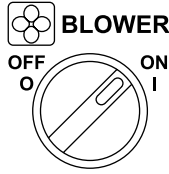

3. Turn the "CONVEYOR" (☸) switch to the "ON" ("I") position.

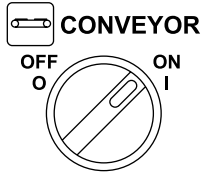

4. If necessary, adjust the conveyor speed setting by pressing the ▲ or ▼ pushbuttons on the conveyor speed controller to change the displayed bake time.

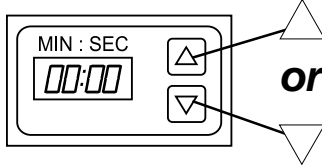

5. Adjust the temperature controller to a desired set temperature, if necessary.

- Press the Set Point and Unlock keys at the same time. Wait for the "SET PT" light to turn on.

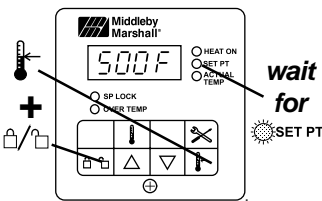

- Press the Up Arrow and Down Arrow Keys as necessary to adjust the setpoint.

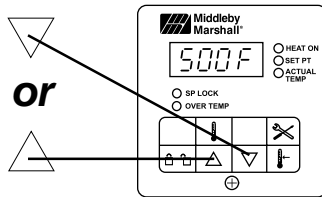

6. Turn the "HEAT" (☸) switch to the "ON" ("I") position, and wait for the "HEAT ON" light to turn on.

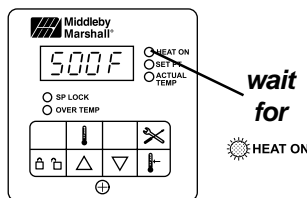

7. Wait for the oven to heat to the setpoint temperature. Higher setpoint temperatures will require a longer wait. The oven can reach a temperature of 500°F (232°C) in approximately 15 minutes.

8. (Optional) Press the Temperature (🌡️) key to show the Actual Temperature in the display, and wait for the "ACTUAL TEMP" light to turn on. This allows you to monitor the oven temperature as it rises to the setpoint.

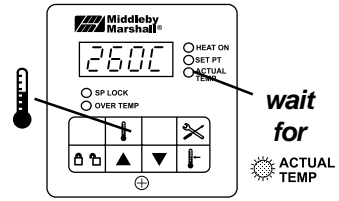

9. Allow the oven to preheat for 10 minutes after it has reached the set point temperature.

B. DAILY SHUTDOWN PROCEDURE

1. Turn the "HEAT" (☸) and "BLOWER" (☸) switches to the "OFF" ("O") position. Note that the blowers will remain in operation until the oven has cooled to below 200°F (93°C).

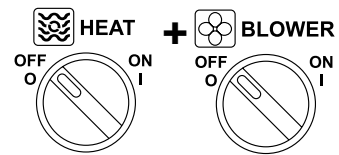

2. Make certain that there are no products left on the conveyor inside the oven. Turn the "CONVEYOR" (☸) switch to the "OFF" ("O") position.

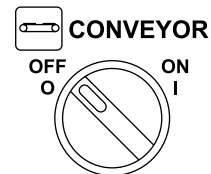

3. After the oven has cooled and the blowers have turned to the "OFF" or "O" position, switch the circuit breaker/fuse disconnect to the "OFF" or "O" position.





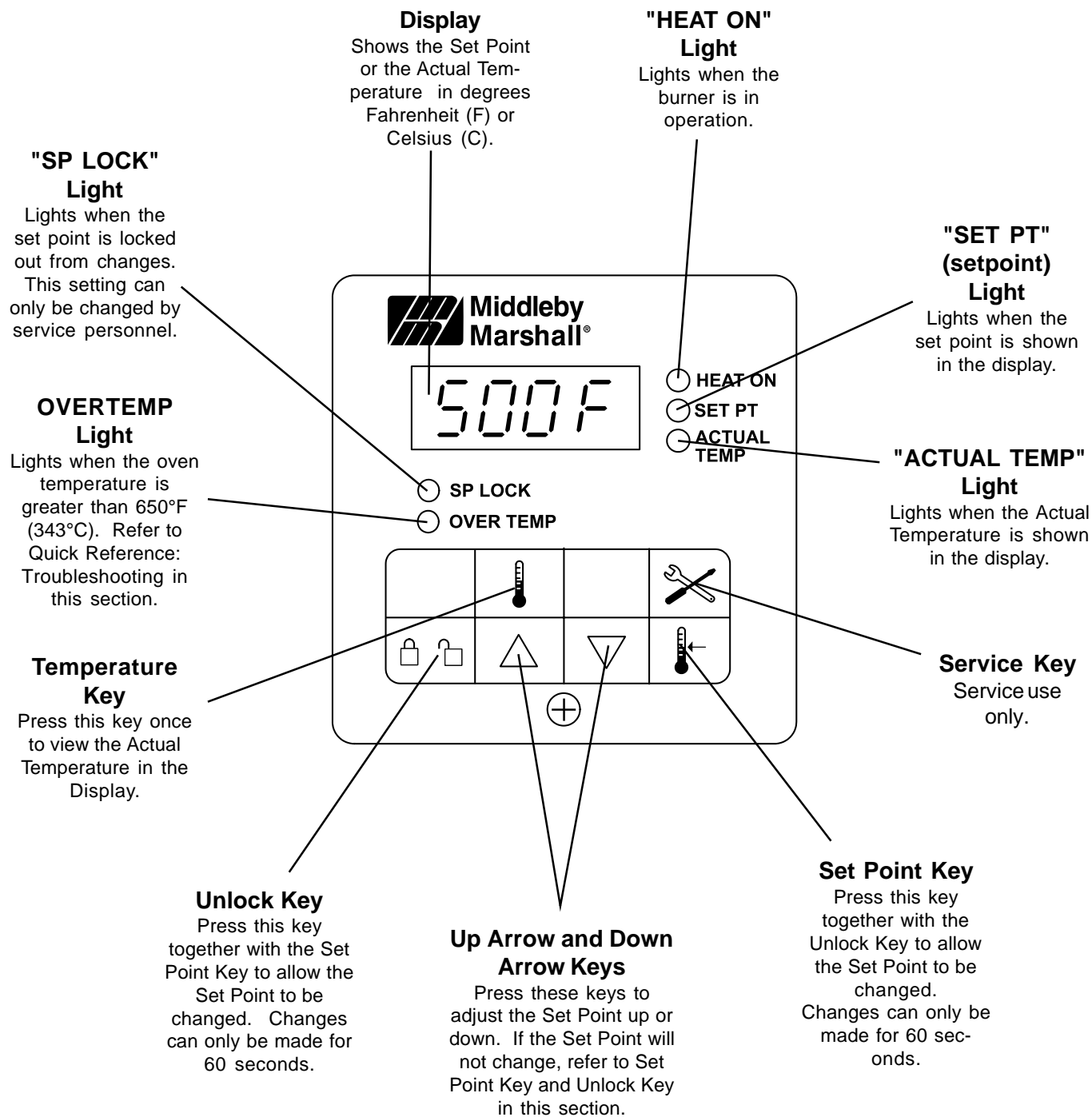





CAUTION

In case of power failure, turn all switches to the "OFF" ("O") position and remove the product. After the power has been restored, perform the normal startup procedure. IF THE OVEN WAS SWITCHED OFF FOR LESS THAN 5 MINUTES, WAIT FOR AT LEAST FIVE MINUTES BEFORE RESTARTING THE OVEN.



SECTION 3
OPERATION

V. QUICK REFERENCE: TROUBLESHOOTING

SYMPTOM	PROBLEM	SOLUTION
<p> OVERTEMP <i>light is lit, food product is undercooked</i></p>	<p>The oven temperature exceeded 650°F (343°C), and the burner was automatically shut down.</p>	<ul style="list-style-type: none"> Follow the procedures under Daily Shutdown Procedures in this section to shut down the oven. Contact your Middleby Marshall Authorized Service Agent to determine and correct the cause of the condition to prevent damage to the oven.
<p><i>Oven will not turn on at all</i></p>	<p>Electrical power may not be reaching the oven, or the controls may be set incorrectly.</p>	<ul style="list-style-type: none"> Check that the circuit breaker/fused disconnect is turned on. Check that the "BLOWER"  Switch is in the "ON" ("I") position.
<p> <i>appears in display, oven is not heating</i></p>	<p>The oven did not reach 200°F (93°C) within 15 minutes of startup, and the oven has stopped heating.</p>	<ul style="list-style-type: none"> Turn the "HEAT" , "BLOWER" , and "CONVEYOR"  switches to the "OFF" ("O") position. Wait for AT LEAST FIVE MINUTES before restarting the oven. Repeat the Daily Startup procedure.
<p><i>Oven will not heat</i></p>	<p>Controls may be set incorrectly.</p>	<ul style="list-style-type: none"> Check that the Set Point is correctly set. Check that both the "BLOWER"  and "HEAT"  Switches are in the "ON" ("I") position. If the oven still will not heat, turn the "HEAT" , "BLOWER" , and "CONVEYOR"  switches to the "OFF" ("O") position. Wait for AT LEAST FIVE MINUTES before restarting the oven. Repeat the Daily Startup procedure. Check that the Set Point is above 200°F (93°C).
<p><i>Oven is operating, but little or no air is blowing from air fingers</i></p>	<p>Air fingers may have been reassembled incorrectly after cleaning.</p>	<ul style="list-style-type: none"> Turn the oven to the "OFF" or "O" position, and allow it to cool. Disconnect electrical power to the oven. Refer to Section 4, Maintenance, for instructions on reassembling the air fingers.
<p><i>Conveyor moves with a jerky motion, or will not move at all</i></p>	<p>Conveyor may be jammed on an object in the oven, or conveyor belt or drive chain tension may be incorrect.</p>	<ul style="list-style-type: none"> Turn the oven to the "OFF" or "O" position, and allow it to cool. Disconnect electrical power to the oven. Check if the conveyor is blocked by an object inside the oven. Refer to Section 4, Maintenance, for instructions on checking the conveyor and drive chain tension.
<p><i>Food products are overcooked or undercooked.</i></p>	<p>Controls may be set incorrectly.</p>	<ul style="list-style-type: none"> Check that the set temperature and bake time settings are correct.

IF THESE STEPS FAIL TO RESOLVE THE PROBLEM, CONTACT YOUR LOCAL MIDDLEBY MARSHALL AUTHORIZED SERVICE AGENT. A SERVICE AGENCY DIRECTORY IS SUPPLIED WITH YOUR OVEN.

SECTION 4 MAINTENANCE

WARNING

Possibility of injury from rotating parts and electrical shock exist in this oven. Turn off and lockout or tagout electrical supply to oven(s) before attempting to disassemble, clean or service oven(s). Never disassemble or clean the oven with the blower switch or any other part of the oven turned on.

WARNING

Before performing any maintenance work or cleaning, turn main power switch off.

CAUTION

When cleaning do not use any abrasive cleaning materials or water spray, wipe clean only. Never use a water hose or pressurized steam cleaning equipment when cleaning this oven.

NOTICE

If the oven is to be removed from its installed location for servicing, perform the following procedure:

1. Switch off the oven and allow it to cool. Do NOT service the oven while it is warm.
2. Turn off main circuit breakers and disconnect connector from oven.
3. Move oven to desired location for servicing.
4. When servicing is complete, move oven to original location.
5. Adjust legs to level oven.
6. Connect electrical connectors to oven.
7. Turn on main circuit breakers.
8. Follow normal startup instructions.

SECTION 4 MAINTENANCE

I. MAINTENANCE - DAILY

A. Exterior

Everyday you should clean the outside of the oven with a soft cloth and mild detergent.

WARNING

Never use a water hose or pressurized steam cleaning equipment when cleaning the oven.

B. Cooling Fan

1. ONE COOLING FAN GRILLE AT THE REAR OF THE OVEN MUST BE CLEANED DAILY - Clean grille with a stiff nylon type brush.

2. Check the air intake of the cooling fan daily. The best time to check is right after starting the oven.

IMPORTANT NOTE

The cooling fan operates when the blower switch is turned to "ON" ("I"). It must operate to keep the electrical control cabinet below 140°F (60°C).

WARNING

IF FAN BLADE IS NOT ROTATING, BROKEN, OR FAN ASSEMBLY IS MISSING FROM MAIN BLOWER MOTOR SHAFT, DO NOT OPERATE OVEN. REPLACE COOLING FAN BLADE BEFORE OPERATING OVEN. Serious damage could be done to the burner blower motor and/or solid-state electrical components if oven is operated while cooling fan is not running or vent grille is plugged.

3. Using a stiff nylon brush clean control compartment vent grille.

C. Conveyor Belt (Figure 4-2)

Everyday, just after starting the oven, stand at the unloading end of the conveyor, and with a brush, remove food particles (crumbs, etc.) clinging to the conveyor belt, brushing them into the crumb pan.

D. Crumb Pans (Figure 4-2)

WARNING

Crumb pan is extremely hot while oven is operating. Allow oven to cool before removing crumb pan.

When the oven is cool remove and clean the crumb pan at each end of the oven. Each crumb pan can be removed by sliding it out, as shown in Figure 4-2. Reinstall the crumb pans after cleaning.

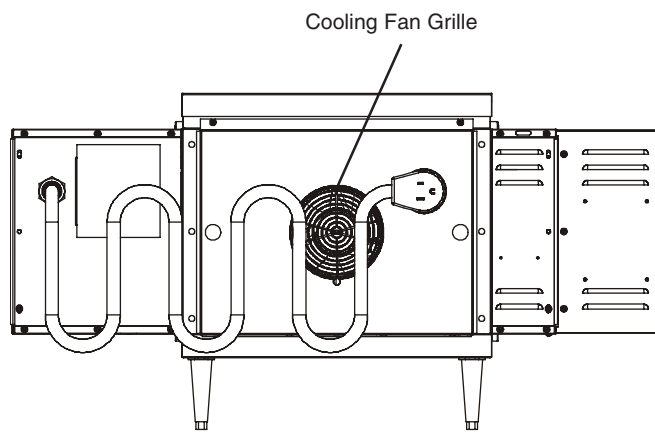

Figure 4-1. Oven Cooling Fans

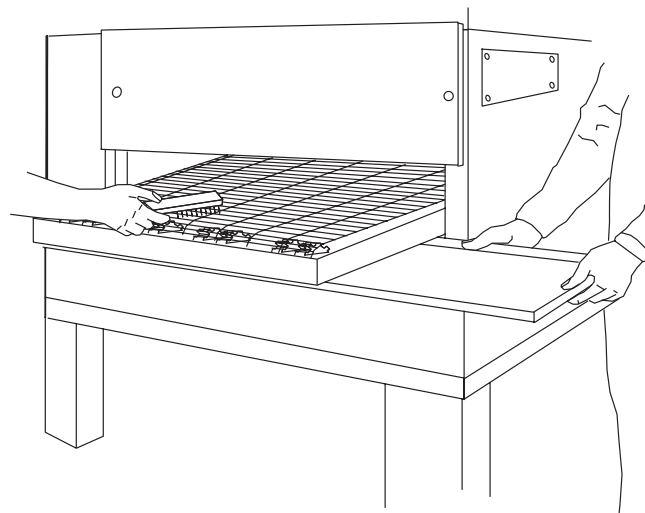

Figure 4-2. Conveyor Belt and Crumb Pan Cleaning

II. MAINTENANCE - MONTHLY

NOTE: The oven interior may require cleaning more than once a month depending on the volume of baking. To clean the interior, you have to disassemble some parts of the oven.

When cleaning your Series PS520 Oven note the following:

PRECAUTIONS-

1. Do not use excessive water or saturation of oven insulation will occur.
2. Do not use a caustic oven cleaner or the aluminized finger manifold surfaces will be severely damaged.

When cleaning your oven, first remove all heavy debris with a vacuum cleaner. Use a damp cloth for light cleaning. For heavier cleaning of baked on grease and carbon deposits use a non-caustic cleaner that will not react with

the aluminized finger manifold surfaces.

You can order non-caustic cleaner from your local authorized Middleby Marshall Parts Distributor in the quantities listed below:

Part #	Quantity
27170-0244	Case of Quarts (6)
27170-0246	Case of Gallons (4)

A. Removing Conveyor From Oven For Cleaning

1. Remove entry and exit trays.
2. Loosen (do not remove) two screws on housing guard.
3. Remove motor housing guard.
4. Lift conveyor and remove chain.

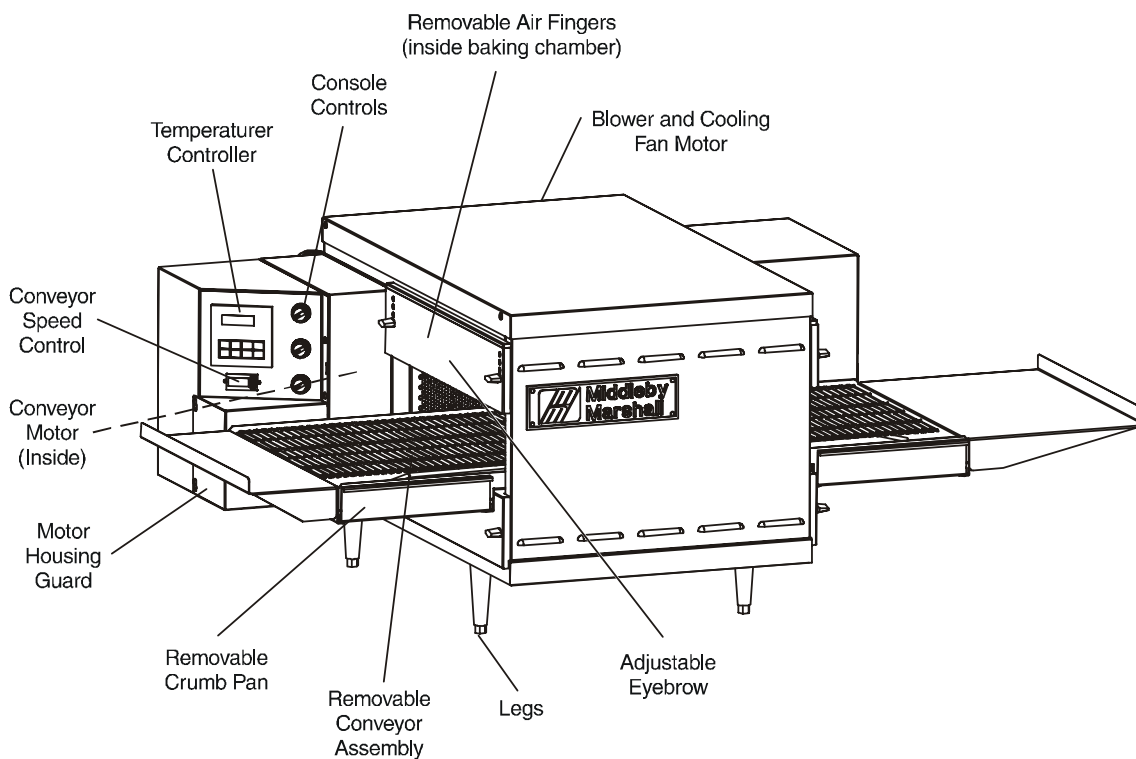

Figure 4-3.

SECTION 4
MAINTENANCE

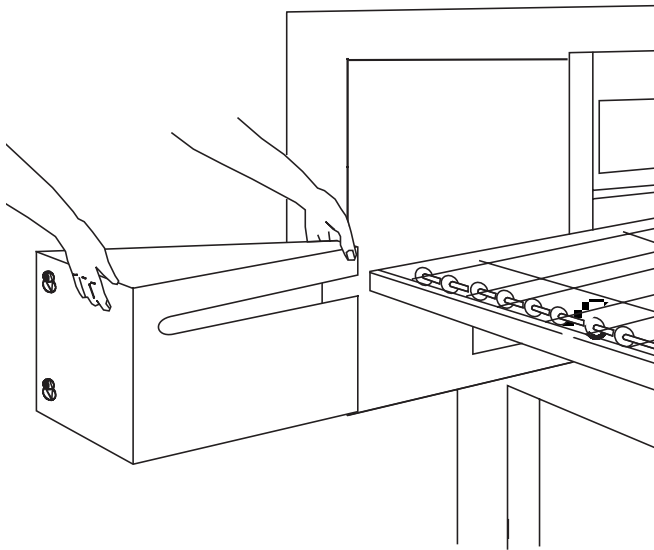

Figure 4-4.

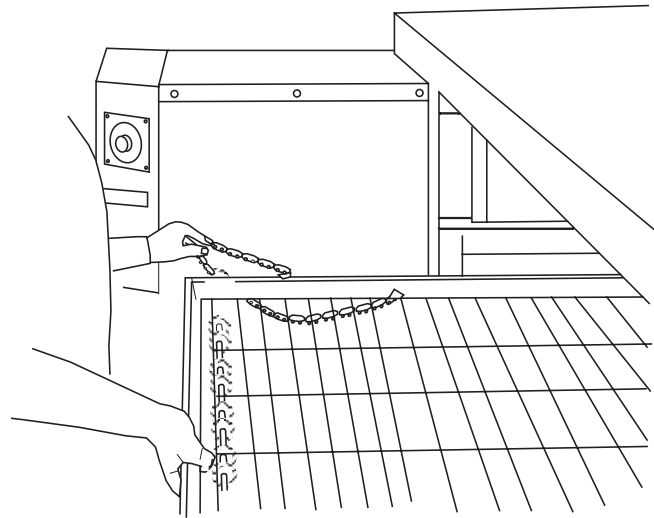

Figure 4-5.

5. Lift other side of conveyor and push toward other side.
6. Remove conveyor as shown.

Figure 4-6.

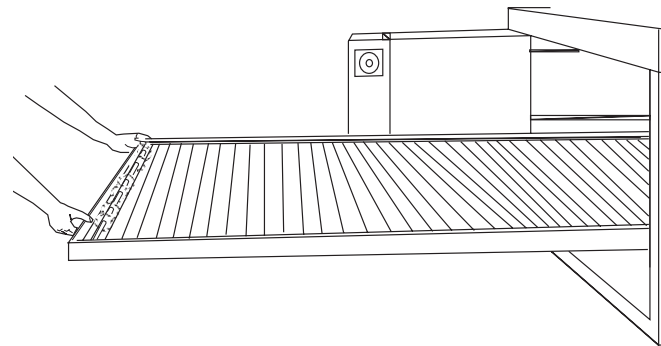
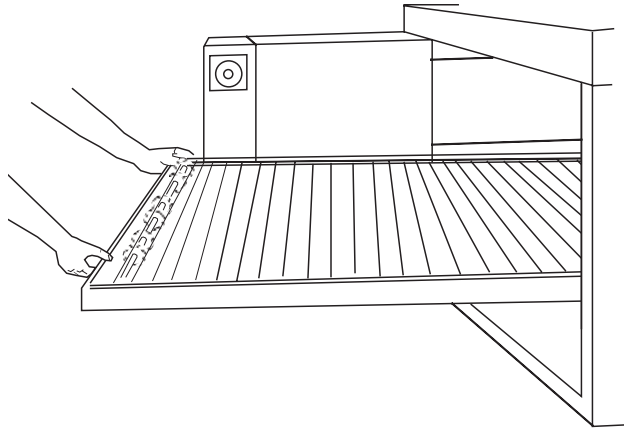

Figure 4-7.

CAUTION

Be careful not to bump the drive sprocket while handling the conveyor, to avoid damaging the drive shaft.

B. Air Fingers Disassembly For Cleaning

1. As the air fingers are removed use a felt pen to mark all parts of the fingers. This includes the finger manifold, inner plate and the outer plate (refer to Figure 1-9). If a blank or choke plate is used, mark that plate also. Fingers are marked in the order shown; as viewed from the front of the oven. (The marks for an upper oven should be preceded with a "U", example UB1, UT2, etc.)

Standard Fingers

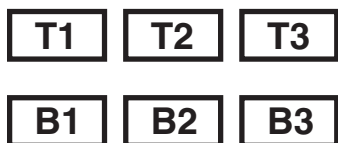

2. Slide blank plates straight out.

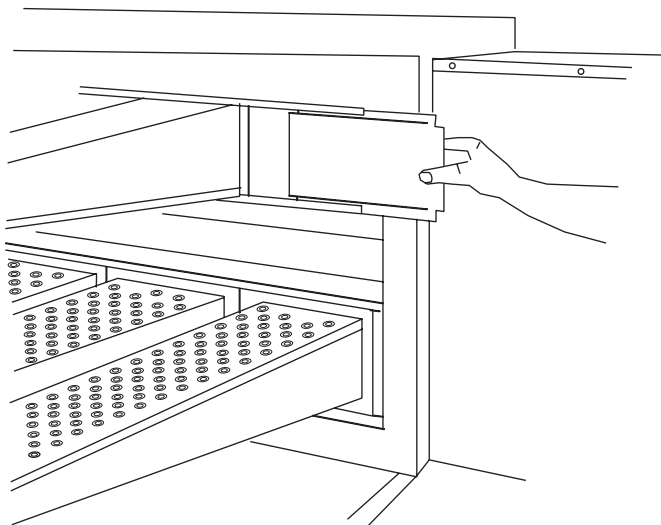

Figure 4-8.

3. Remove air fingers.

NOTE: Some oven users require a custom finger arrangement where the quantity of air fingers may vary.

You can remove top and bottom fingers and blank plates from each or either end. It is highly recommended that each finger be marked before removing so it is placed in exactly the same position when reassembled (refer to step 1).

Remove the air fingers, pull the finger at the back side - pull straight out.

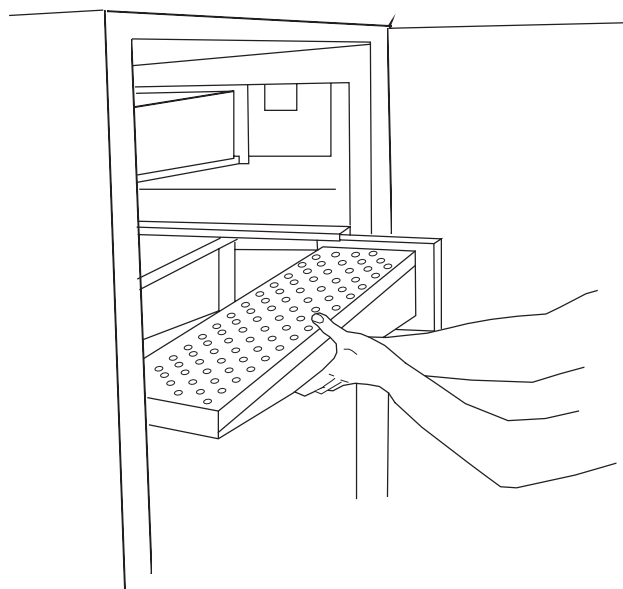

Figure 4-9.

4. With air fingers out, place them in an upright position to remove the outer plate.

5. Gently step on the lip of the finger and pull the outer plate off.

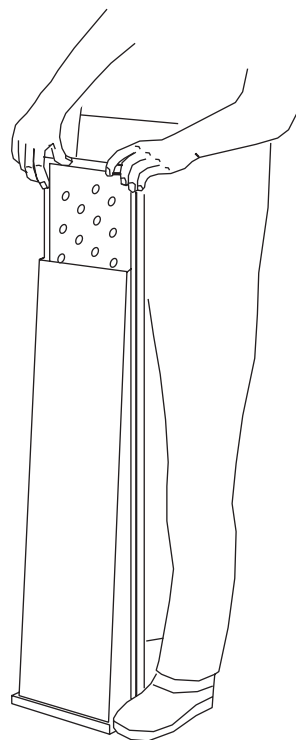

Figure 4-10.

SECTION 4 MAINTENANCE

6. To remove the inner plate, pull the plate out and then up.

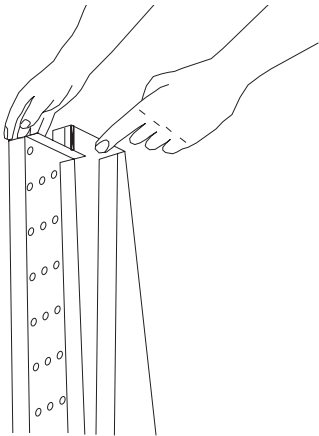

Figure 4-11.

7. The outer finger plate is stainless and may be cleaned by either soaking in a hot, strong detergent solution or using a caustic cleaner. The conveyor belt can also be cleaned in the same way.

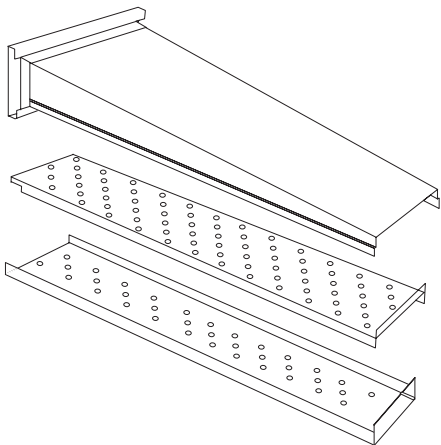

Figure 4-12. Standard Lower Finger

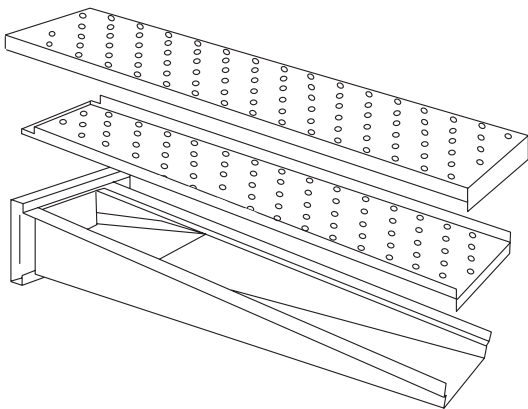

Figure 4-13. Standard Upper Finger

C. Reassembly of Air Fingers

1. Air fingers are made up of one inner plate, one outer plate and the finger housing manifold. Be sure to match up the markings (T1, T2, T3, etc.) on all the parts of the air fingers as you are reassembling.

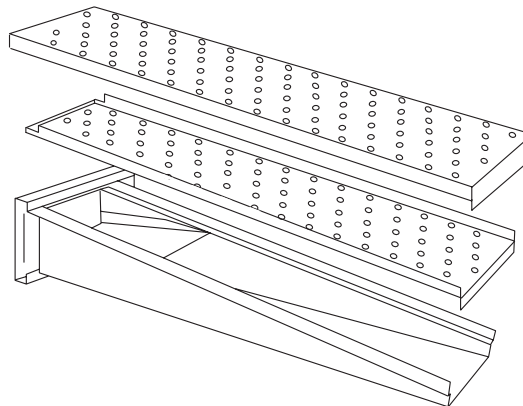

Figure 4-14.

2. Reassemble the inner plate. Keep your fingers clear so you won't pinch them. The inner plate of a finger will only go in one way because of its design.

3. Replace the outer plate by placing your hands flat on the top of the plate and pushing down. Keep your fingers clear so you won't pinch them.

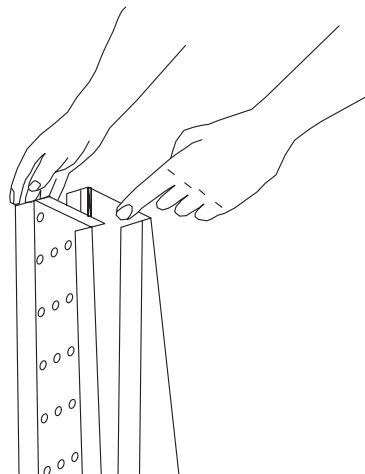
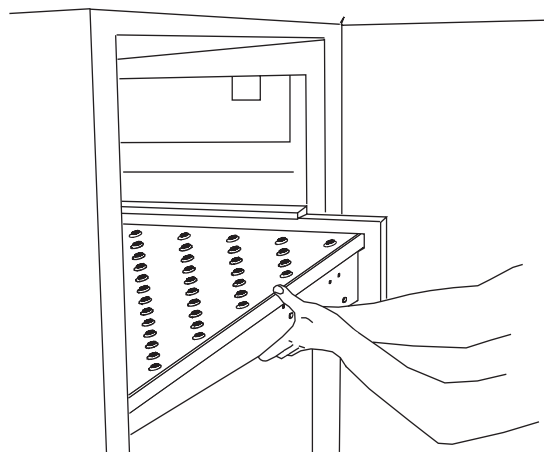

Figure 4-15.

4. Replace the air fingers by pushing in at the back side. Remember to replace them according to the numbers marked on them when they were removed. They must go back in the same way they came out.

IMPORTANT: When inserting fingers the tab on the outer plate must be in the groove as shown in Figure 4-18. There is a blocking tab on the outside of the groove which will prevent inserting the finger in the groove if the outer plate is moved away from the flange of the finger manifold.



Figure

4-16.

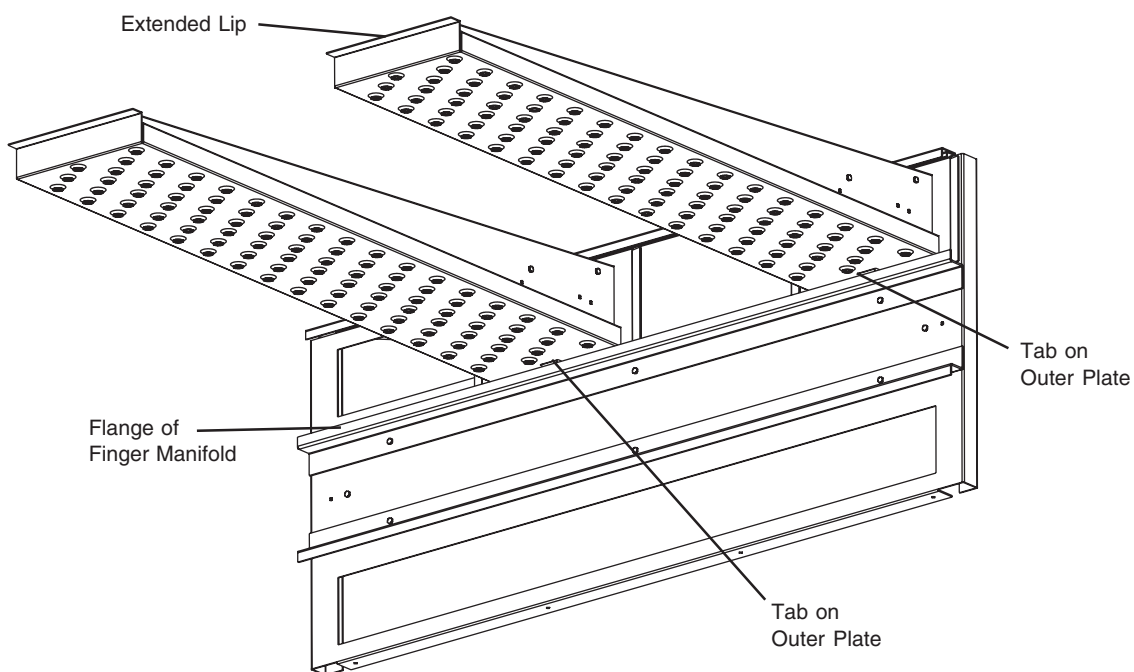

Figure 4-17.

SECTION 4 MAINTENANCE

5. Install fingers and blank plates correctly with edges interlocked and no space between edges.

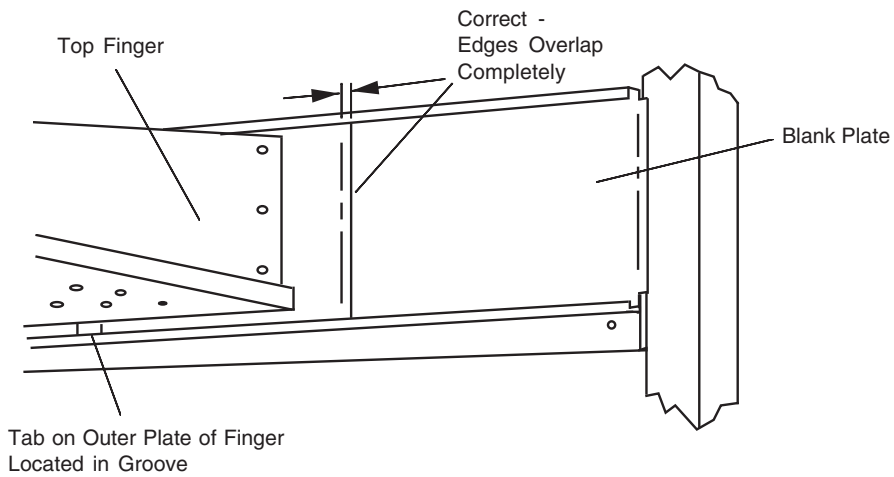
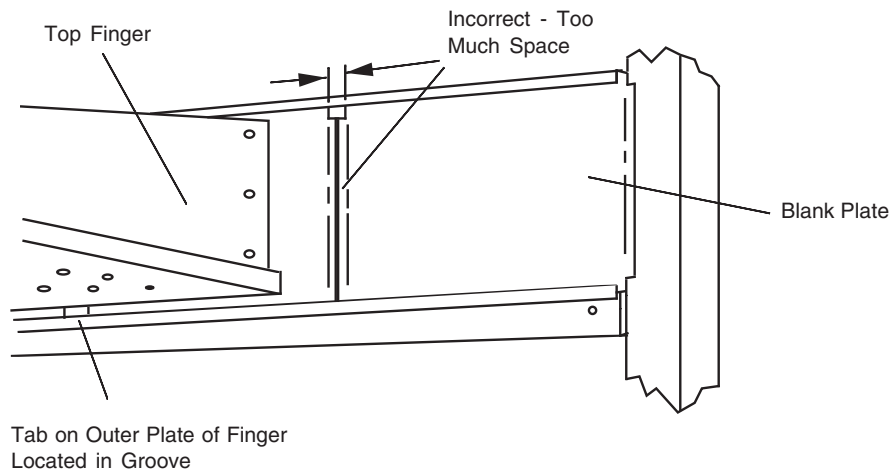
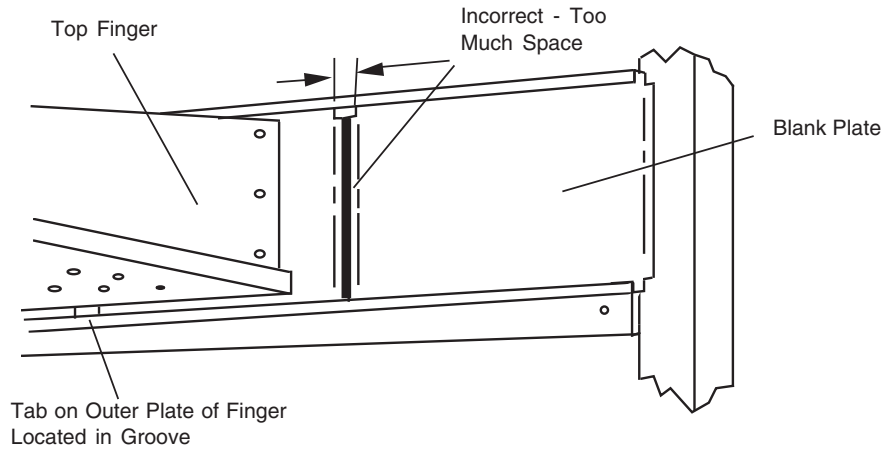

Figure 4-18.

D. Reinstall End Plugs

1. Reinstall lower end plug. Be sure to tighten the wing screw on the end plug.
2. Reinstall conveyor.
3. Reinstall upper end plug. Be sure to tighten two wing screws on the end plug.

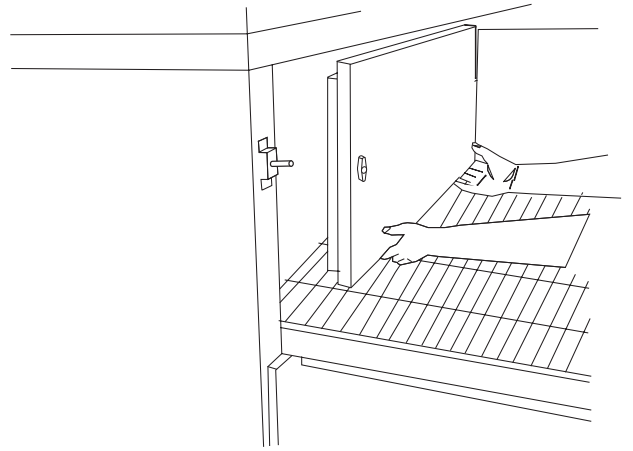

Figure 4-19.

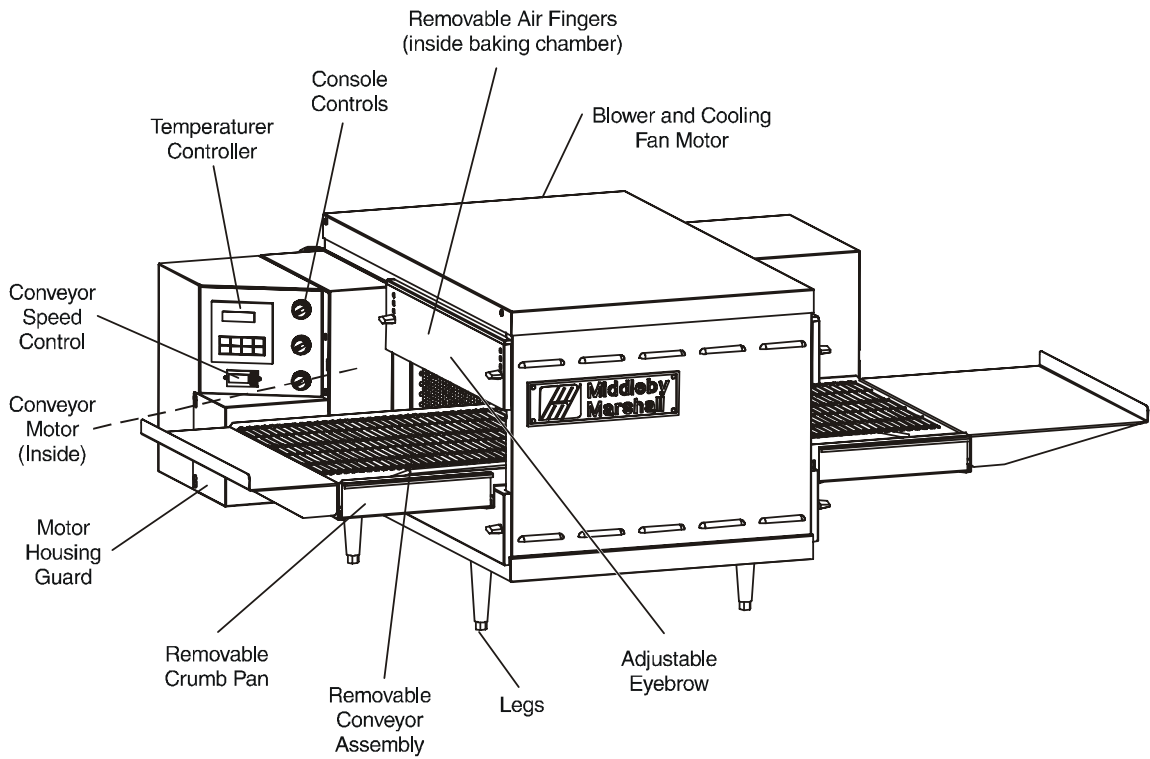

Figure 4-20.

SECTION 4 MAINTENANCE

E. Conveyor Reassembly Into Oven

1. Lift conveyor and position it in oven as shown.

NOTE: Conveyor may be inserted into either end of oven. If it is to be installed from the non-drive end of the oven the drive sprocket assembly must be removed as shown in conveyor disassembly section.

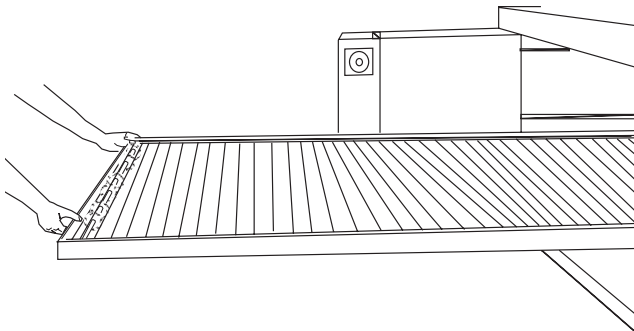

Figure 4-21.

2. Reinstall the conveyor extension.

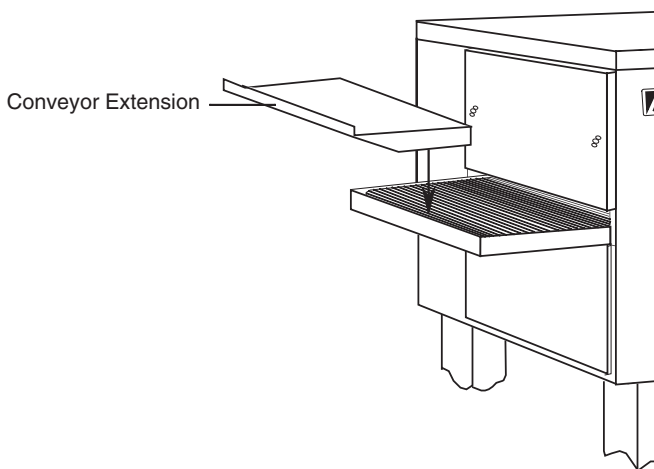

Figure 4-22.

F. Checking Conveyor Belt Tension

WARNING

Oven conveyor belt must be cool when adjusting belt. Do not adjust belt if HOT.

1. With the conveyor assembly in the oven, stand at one end of conveyor and check tension by lifting the conveyor belt at the center of the oven chamber opening. The belt should not lift higher than 1" to 2" (75mm to 102mm).
2. If conveyor belt is still not under proper tension, an entire link must be removed. Use the following procedure "H. Conveyor Belt Link Removal" to remove a link. If conveyor belt is under proper tension proceed directly to "J. Attaching Drive Chain".

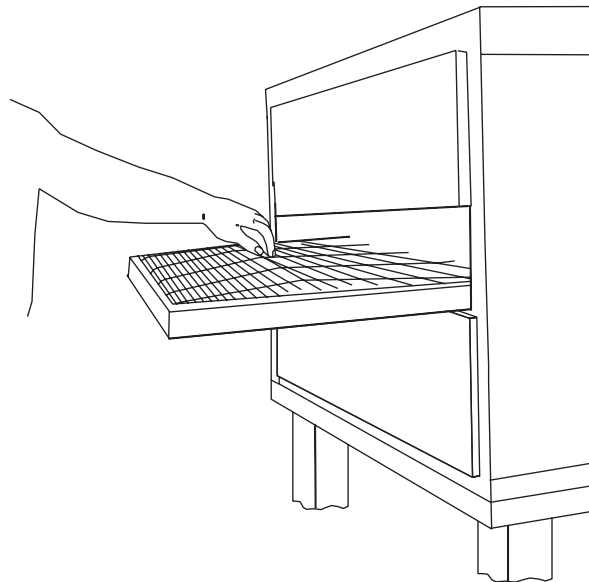

Figure 4-23.

G. Conveyor Belt Link Removal

1. Using long nose pliers, an entire link can be removed with the conveyor assembly either in or out of the oven. Position master links at end of conveyor as shown in Figure 4-24.

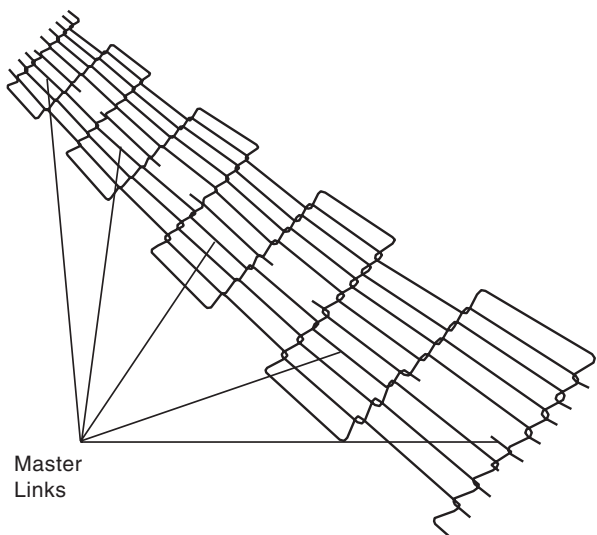

Figure 4-24.

2. Using long nose pliers, unhook master links at left end of conveyor as shown in Figure 4-25.

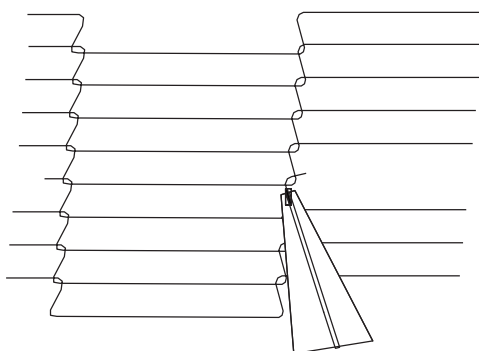

Figure 4-25.

3. Remove the outside master links on the right and left sides of the conveyor belt as shown in Figure 4-26.

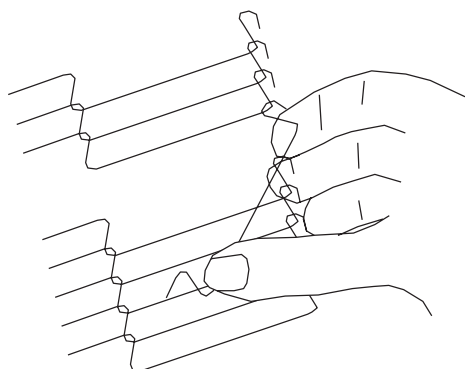

Figure 4-26.

4. Unhook the link to be removed.

5. Pull up on the belt link section and remove. Do not discard the link removed as it may be used for making spare master links.

NOTE: If a section of the conveyor belt is being replaced it should be done now. Remove the links that need replacing and use the section of conveyor belt furnished in your installation kit to replace them.

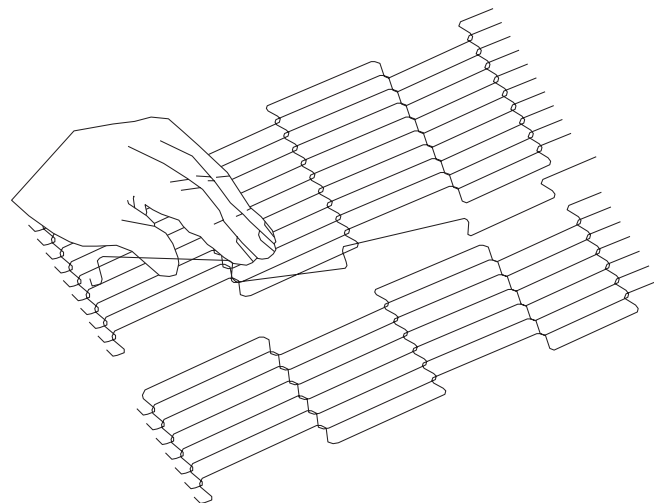

Figure 4-27.

NOTE: Before connecting the inside master links, notice that these links have a correct position (Figure 4-28). The link at the right is in the correct (horns up) position for inserting into the conveyor belt. The horns facing down are in the incorrect position.

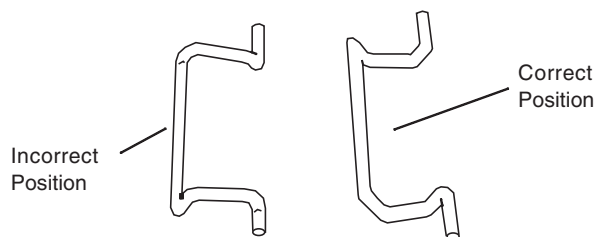

Figure 4-28.

SECTION 4 MAINTENANCE

6. Reconnect the inside master links (Figure 4-29.)

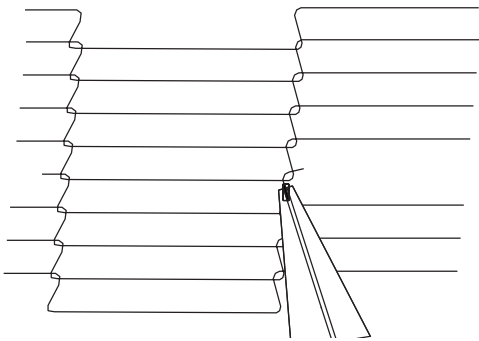

Figure 4-29.

NOTE: The outside master links have right and left sides to them. The right edge master link has an open hook facing you as shown in Figure 4-30. This will match up with the outer edges of the conveyor belt. Remember this hook travels backwards on the conveyor.

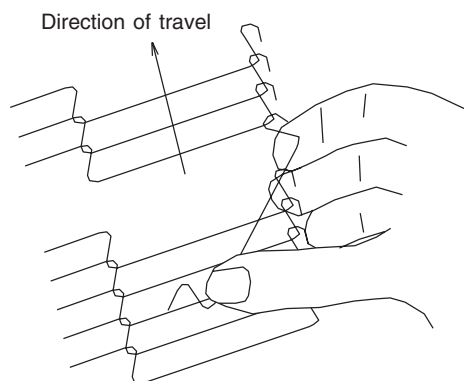

Figure 4-30.

7. Reconnect the outside master links.

8. Replace all parts removed from the oven.

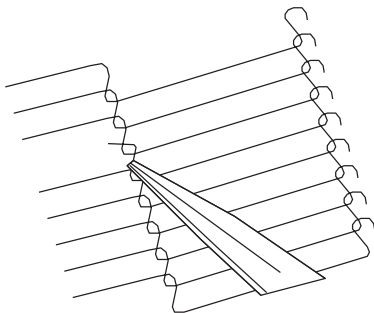

Figure 4-31.

H. Attaching Drive Chain

1. If drive sprocket assembly was removed reassemble it into the conveyor drive shaft. Be sure flat on end of drive shaft aligns with set screw in conveyor shaft collar. Once in place tighten 3/32" set screw.

2. Lift conveyor and install drive chain to conveyor drive sprocket and motor sprocket.

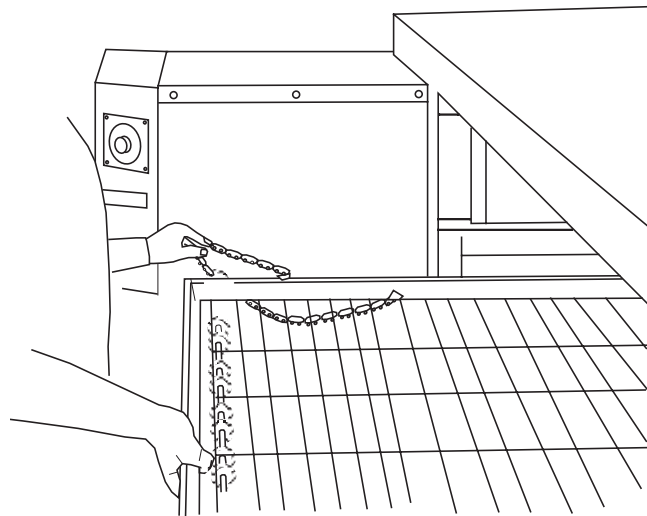

Figure 4-32.

3. The angle plate located on the underside of the conveyor must be against the lower end plug. This is true on both sides of oven.

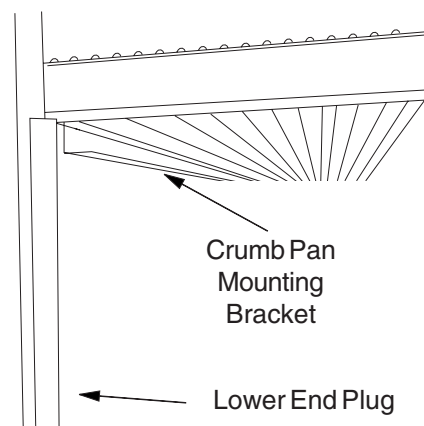

Figure 4-33.

4. Reattach conveyor guard to control panel and secure two screws.

Install both upper end plugs.

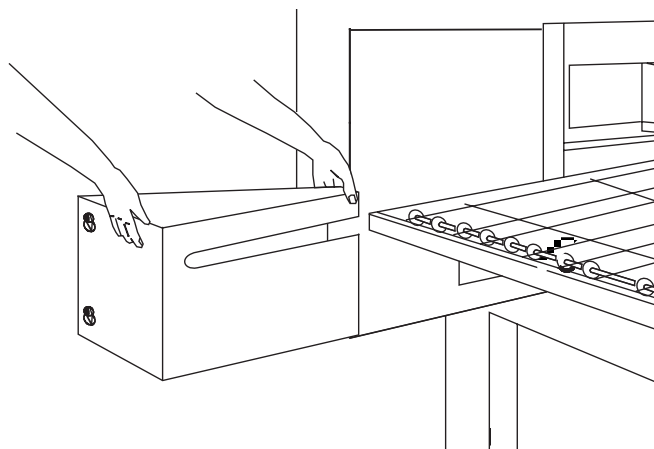

Figure 4-34.

III. MAINTENANCE - EVERY 3 MONTHS

WARNING

Shut OFF all electrical power and lock/tag out the switch before attempting maintenance work.

NOTE: It is recommended that the 3-month maintenance be performed by an authorized Middleby Marshall technician.

A. Electrical Terminals

Open the control cabinet door by removing the three screws from the control cabinet door. Tighten all electrical control terminal screws including the electrical contactor terminal screws as shown in Figure 4-35.

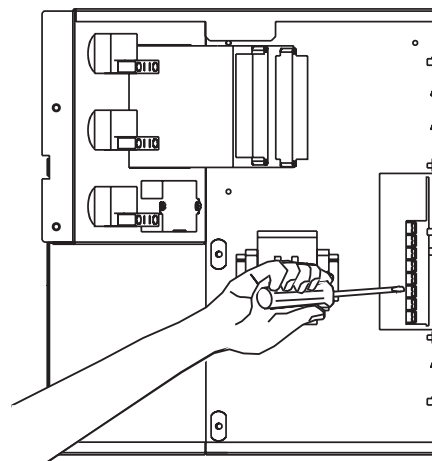

Figure 4-35.

B. Ventilation

Check that the air circulation throughout the oven is not blocked and is working properly.

IV. MAINTENANCE - EVERY 6 MONTHS

A. Check brushes on D.C. conveyor motor, when worn to less than 1/10" (2.4mm), replace the brushes.

B. Check your oven venting system.

IMPORTANT NOTICES:

- Installation of replacement parts requiring access to the interior of the oven is permitted only by an authorized service technician.
- If there are any problems with the operation of the oven, the authorized service technician must be called.
- It is suggested to obtain a service contract with a manufacturer's authorized service technician.

SECTION 4
MAINTENANCE

KEY SPARE PARTS KIT

An oven can be purchased with a Key Spare Parts Kit (Figure 4-36). (The kit can be purchased when the oven is ordered, or later, from a Middleby Marshall Authorized Parts Distributor). The kit contains many of the crucial

parts that can reduce serious downtime and loss of production, if a failure occurs.

Replacement parts for this kit can be purchased from your Middleby Marshall Authorized Parts Distributor.

PS520-SERIES ELECTRIC OVEN KEY SPARE PARTS KIT (Figure 4-36)

ITEM	PART NO.	ENGLISH DESCRIPTION	QUANTITY
1	47321	Kit, Temperature Control On/Off Pid	1
2	51402	Relay, 100A	1
3	58500	Conveyor Drive Motor and Magnet	1
4	60542	Conveyor Speed Control	1
5	33812-5	Thermocouple*	1
6	50715	Heater Element, 208V	1
6	51017	Heater Element, 240V	1
6	51958	Heater Element, 380V	1
6	51961	Heater Element, 480V	1
7	57408	Contactors	1
8	60598	Air Switch	1

* The proper location for the thermocouple is as follows: 1) Temperature sensing is located on the entrance end of the unit on the bottom, 2) High limit is located on the exit end of the unit on the top, 3) High limit on the PS520 is 600 degree's.

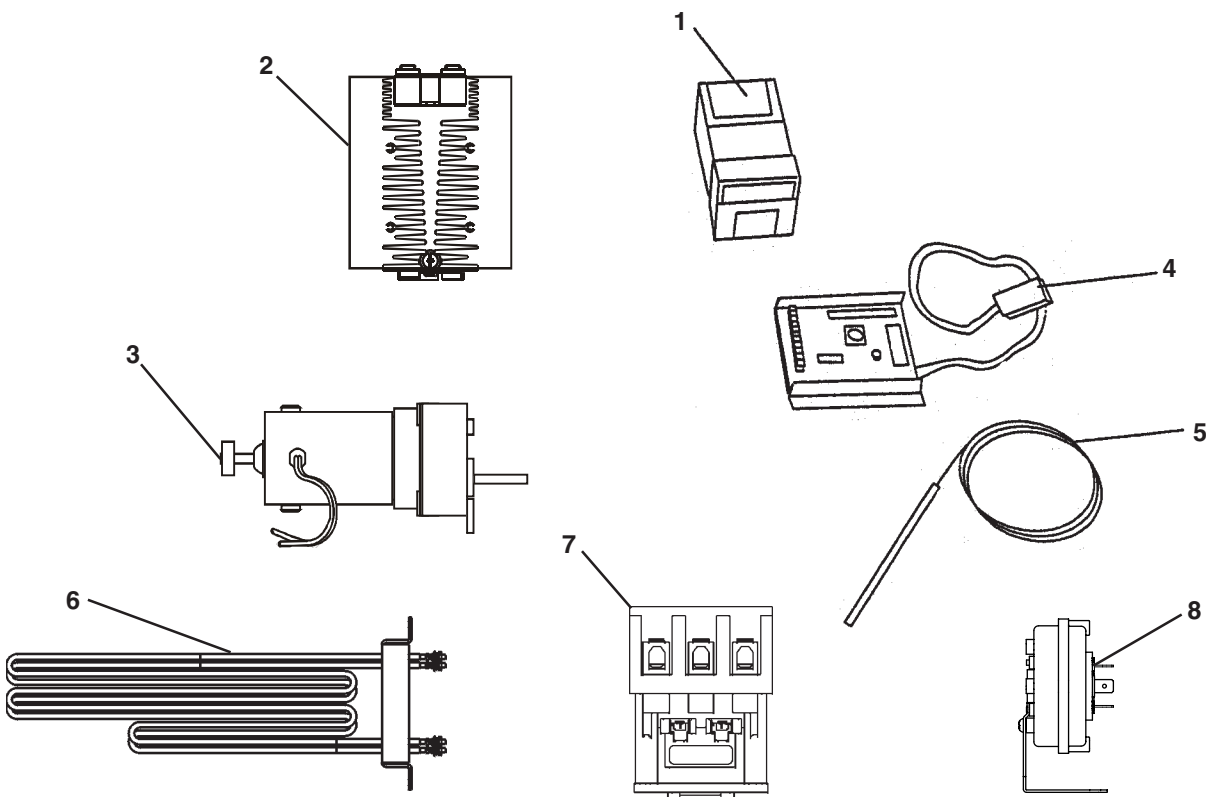
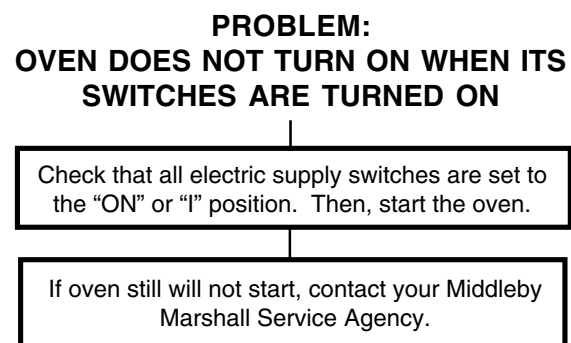
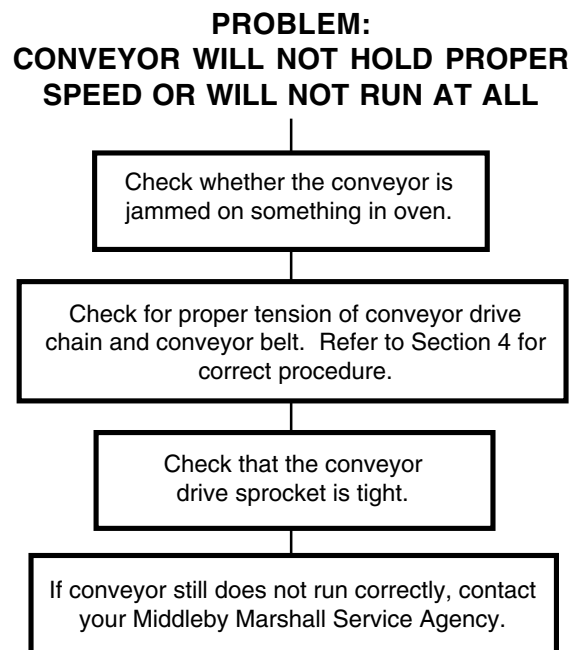
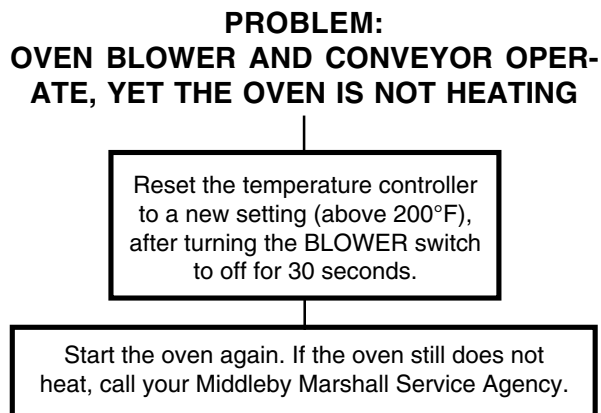
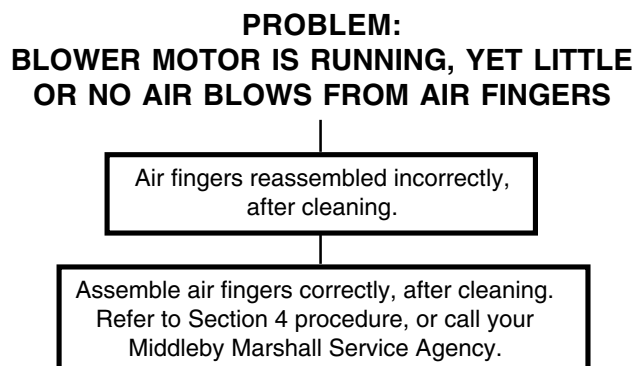
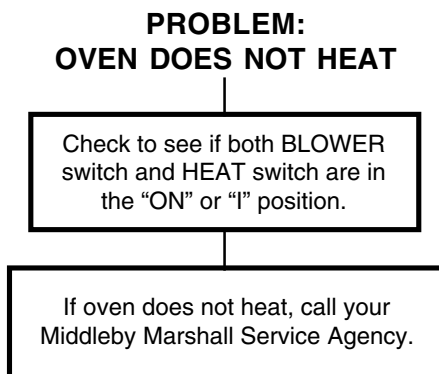
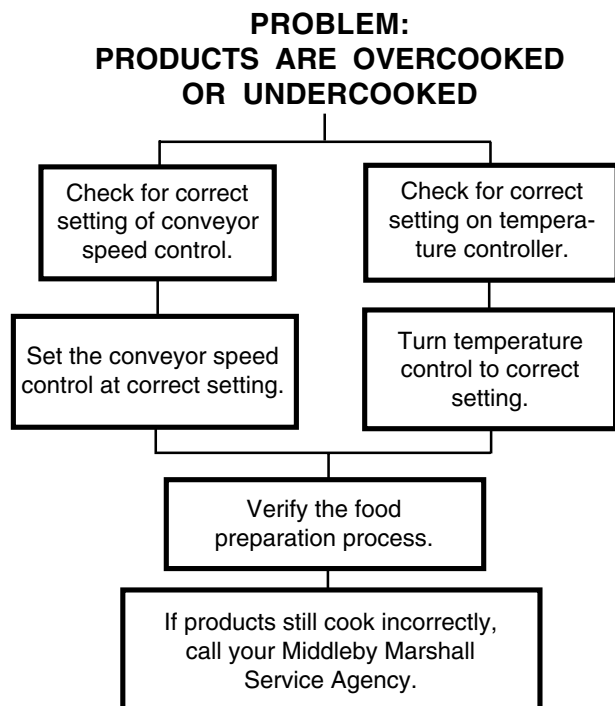

Figure 4-36.

SECTION 5 TROUBLESHOOTING



NOTES

SECTION 6 - PARTS LIST

SECTION 6
PARTS LIST

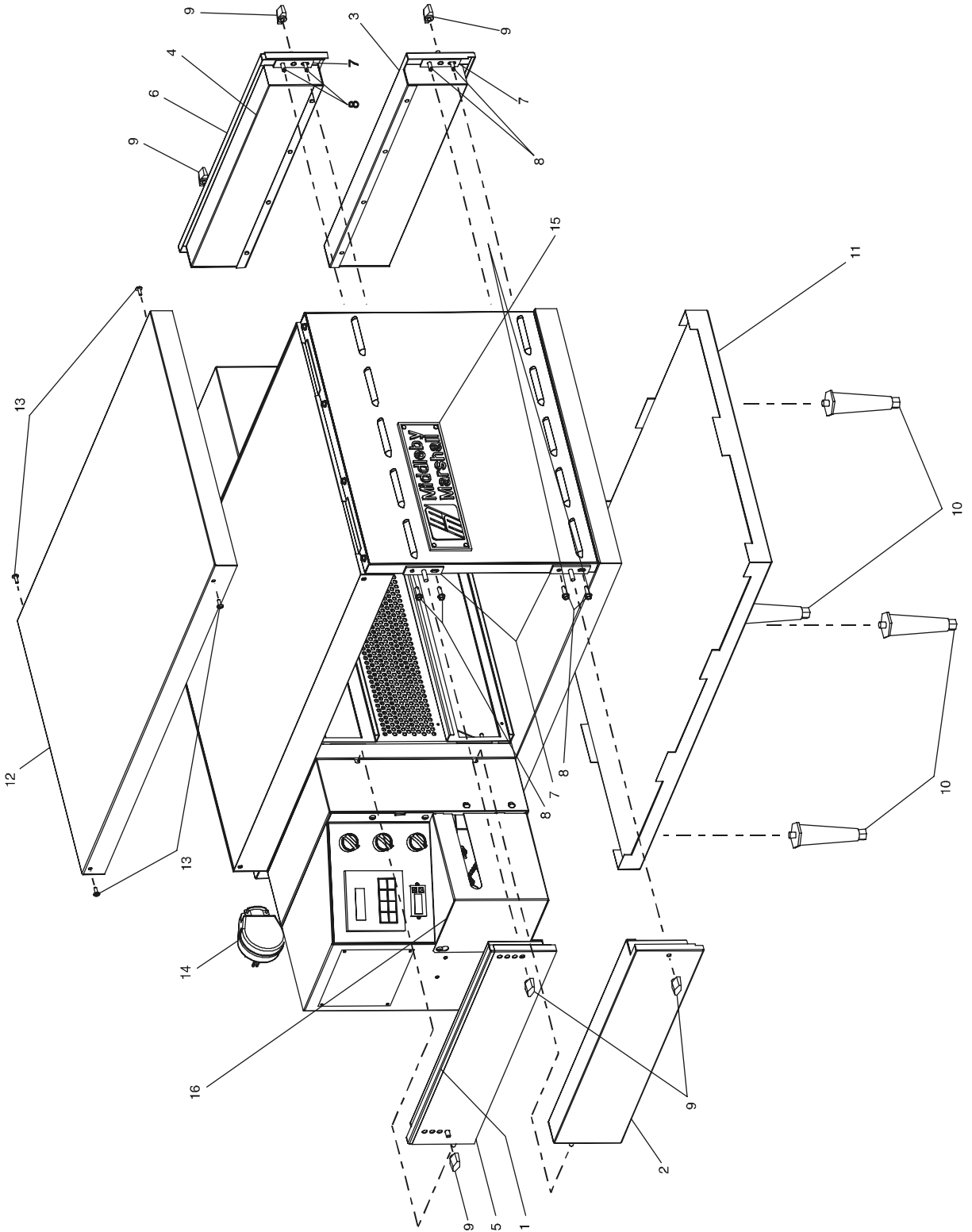

SINGLE OVEN EXPLODED VIEW

ITEM	QTY	PARTNO.	DESCRIPTION
1	1	48382	UPPER LH END PLUG ASSEMBLY (INCLUDES ITEM 5 EYEBROW)
2	1	48387	LOWER LH END PLUG ASSEMBLY
3	1	48408	LOWER RH END PLUG ASSEMBLY
4	1	48412	UPPER RH END PLUG ASSEMBLY (INCLUDES ITEM 6 EYEBROW)
5	1	48378	EYEBROW, UPPER LH END PLUG ASSEMBLY
6	1	48410	EYEBROW, UPPER RH END PLUG ASSEMBLY
7	4	51398	END PLUG MOUNTING BRACKET ASSEMBLY .875
8	8	21296-0005	SCREW, HEX HEAD, WSHHD 12-14X3/4 SS BSD
9	6	36452	NUT, WING-PLASTIC 1/4-20
10	4	3101908	LEG, 4" ADJ FT (NPS)
11	1	48395	BOTTOM TRAY ASSEMBLY
12	1	48396	COVER, TOP
13	4	51387	SCR, MS, SLT TRHD 8-32X1/2 18-8
14	1	M10434	CORDSET, 50 AMP 250V 2P 3W (208/240 V MODELS ONLY)
15	1	45739	NAMEPLATE, MM
16	1	47862	ASSY, COVER, MOTOR

SECTION 6
PARTS LIST

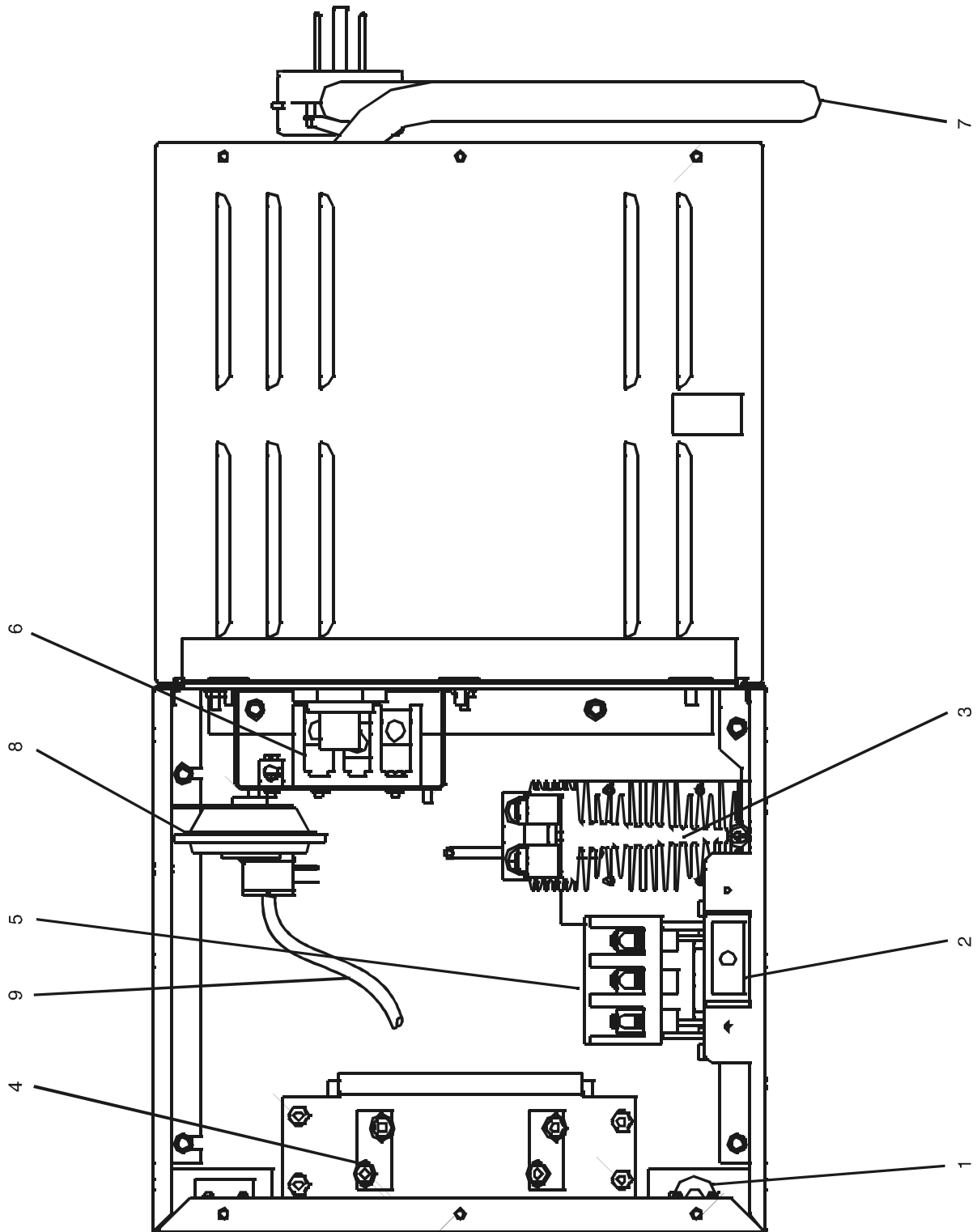

RELAY PANEL

ITEM	QTY	PARTNO.	DESCRIPTION
1	1	33812-5	THERMOCOUPLE, TYPE "J", SHIELDED 2.50X120"
2	1	28021-0047	SWITCH, INTERLOCK, 10A, NO2P
3	1	51402	RELAY, HEATSINK480VAC 100A
4	1	51961	ELEMENT, HEATING, 480V
4	1	51958	ELEMENT, HEATING 380V
4	1	51017	ELEMENT, HEATING 240V
4	1	50715	ELEMENT, HEATING, 208V
5	1	57408	CONTACTOR, 208/240V, 65A, 50/60 HZ
6	1	3003946	BLOCK, POWER 3POLES
7	1	M10434	CORDSET, 50 AMP, 250V ,2P 3W (208/240 V MODELS ONLY)
8	1	50610	SWITCH, AIR 0.16 IN. WC
9	1	22450-0297	TUBING, SILICONE, 27"

SECTION 6
PARTS LIST

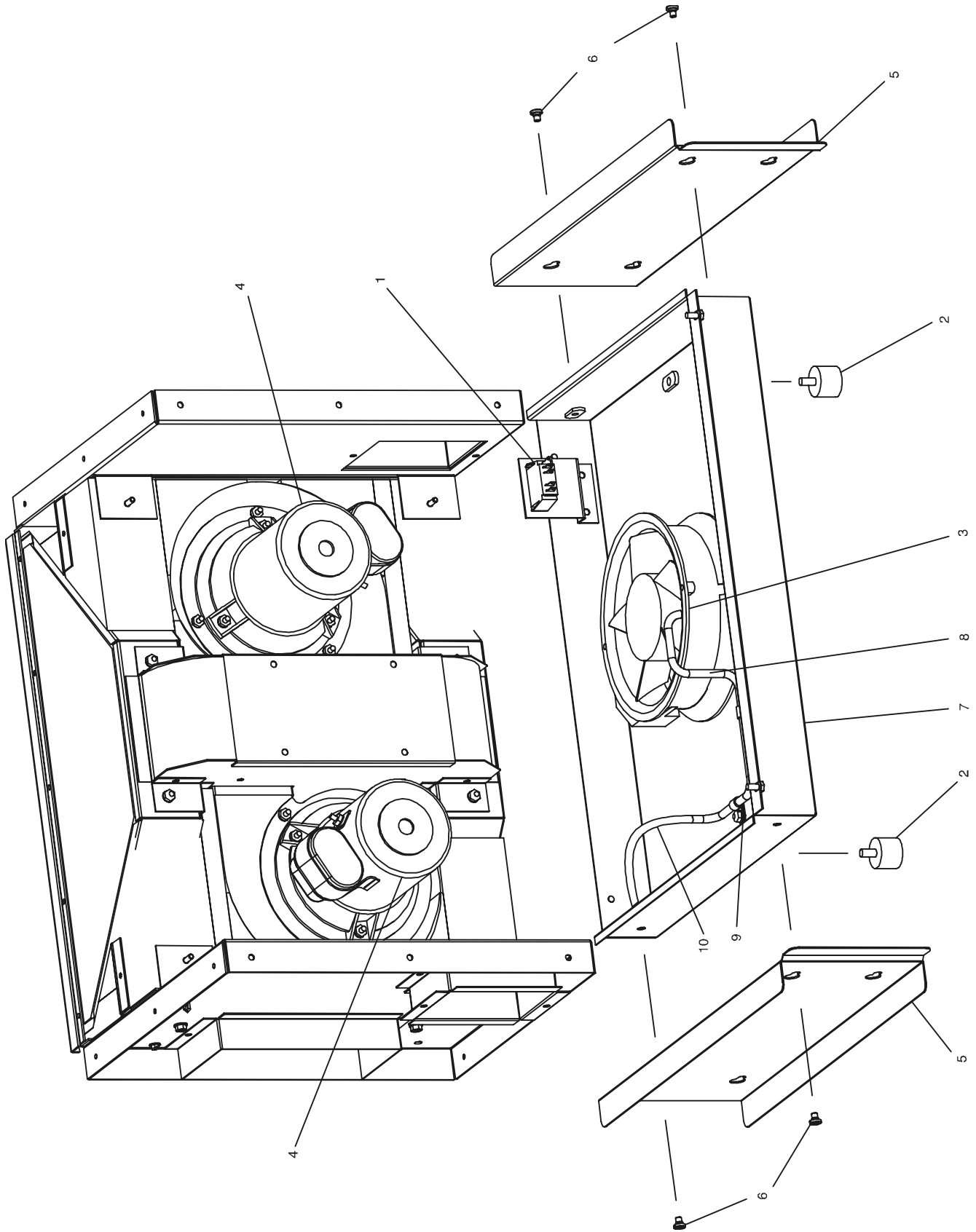

BLOWER ASSEMBLY

ITEM	QTY	PARTNO.	DESCRIPTION
1	1	28021-0061	SWITCH, MOMENTARY-10A, NO 2 POLE
2	2	30927	BUMPER, WINDOW
3	1	51399	FAN, COOLING, 230V AC, 295 CFM
4	2	52244	MOTOR, BLOWER, CW, 208/230 50/60HZ
5	2	57258	PLATE, AIR VENT
6	4	7007413	SCR, SHOULDER 10-32X, 34 18-8
7	1	31497	GUARD, COOLING FAN (NOT SHOWN)
8	1	57474	TUBE, ALUMINUM, 1/4", AIR SWITCH (15125-0002)
9	3	57476	CLAMP, AIR TUBE
10	1	22450-0297	TUBING, SILICONE, 27"

SECTION 6
PARTS LIST

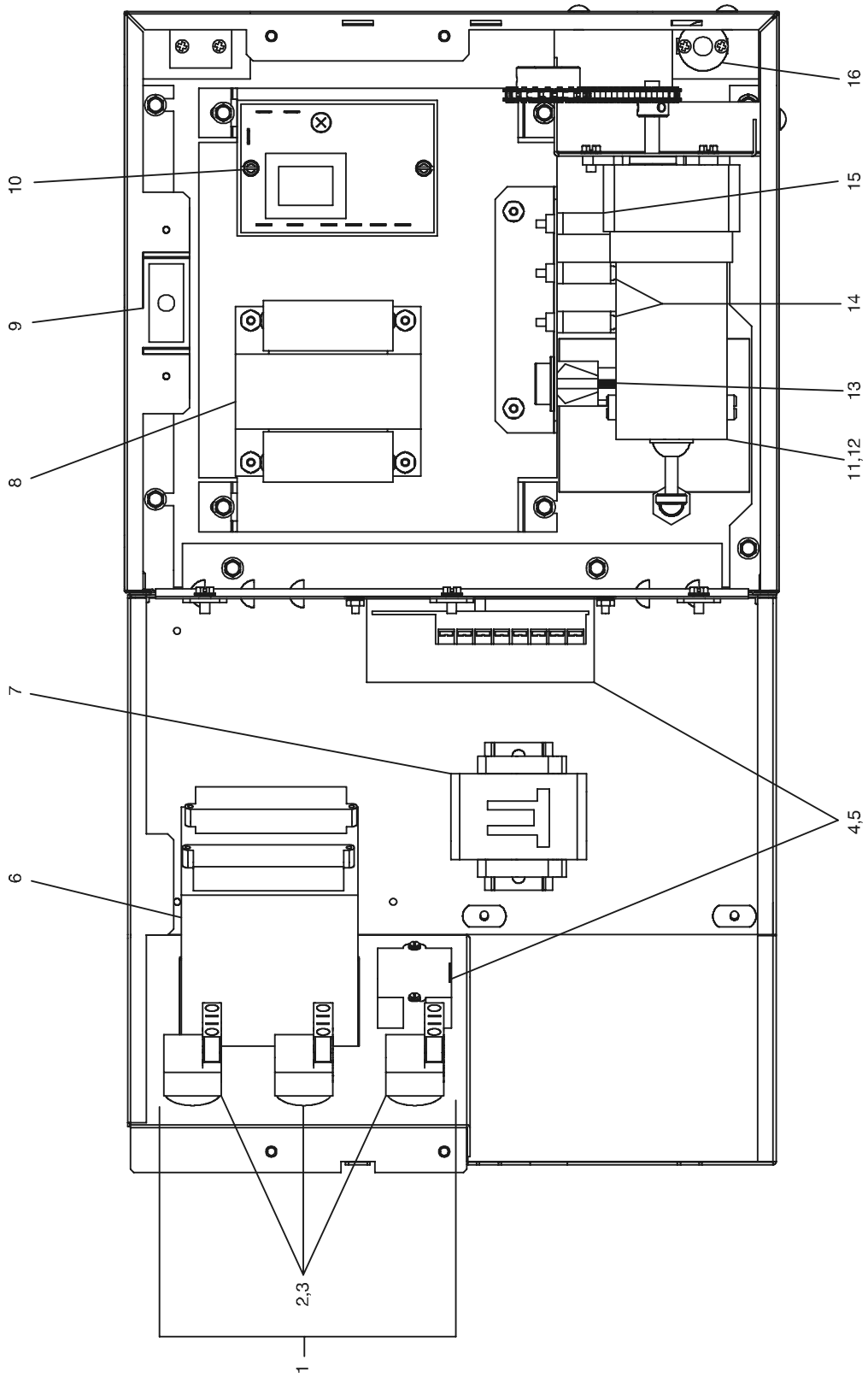

CONTROL PANEL

ITEM	QTY	PARTNO.	DESCRIPTION
1	3	46521	KIT BLOWER SWITCH CONTAINS ((1) 44697, (1) 44696))
2	3	44697	CONTACT BLOCK
3	3	44696	SELECTOR SWITCH
4	1	60542	CONVEYOR SPEED CONTROL W/DIGITAL SPEED DISPLAY
5	1	37503	DIGITAL SPEED CONTROL (DISPLAY ONLY)
6	1	50990	CONTROL, COMBO 4-20MA BURST
7	1	28041-0011	CONTACTOR, 208/240V
8	1	31504	TRANSFORMER, 230V(P)/120V(S), 200VA
9	1	28021-0047	SWITCH, INTLCK, 10A, NO2P
10	1	33983	CONTROL, ELECTRIC, HI-LIMIT, 240V
11	1	58500	MOTOR, CONVEYOR DRIVE
12	1	50163	KIT, CONVEYOR PICK-UP
13	1	35145	SWITCH, PUSHBUTTON, MOLVENO, 250V
14	2	45036	BREAKER, CIRCUIT 240V, 3A
15	1	48635	BREAKER, CIRCUIT 240V, 0.3A
16	1	33812-5	THERMOCOUPLE, TYPE "J", SHIELDED, 2.50X1 20"

SECTION 6
PARTS LIST

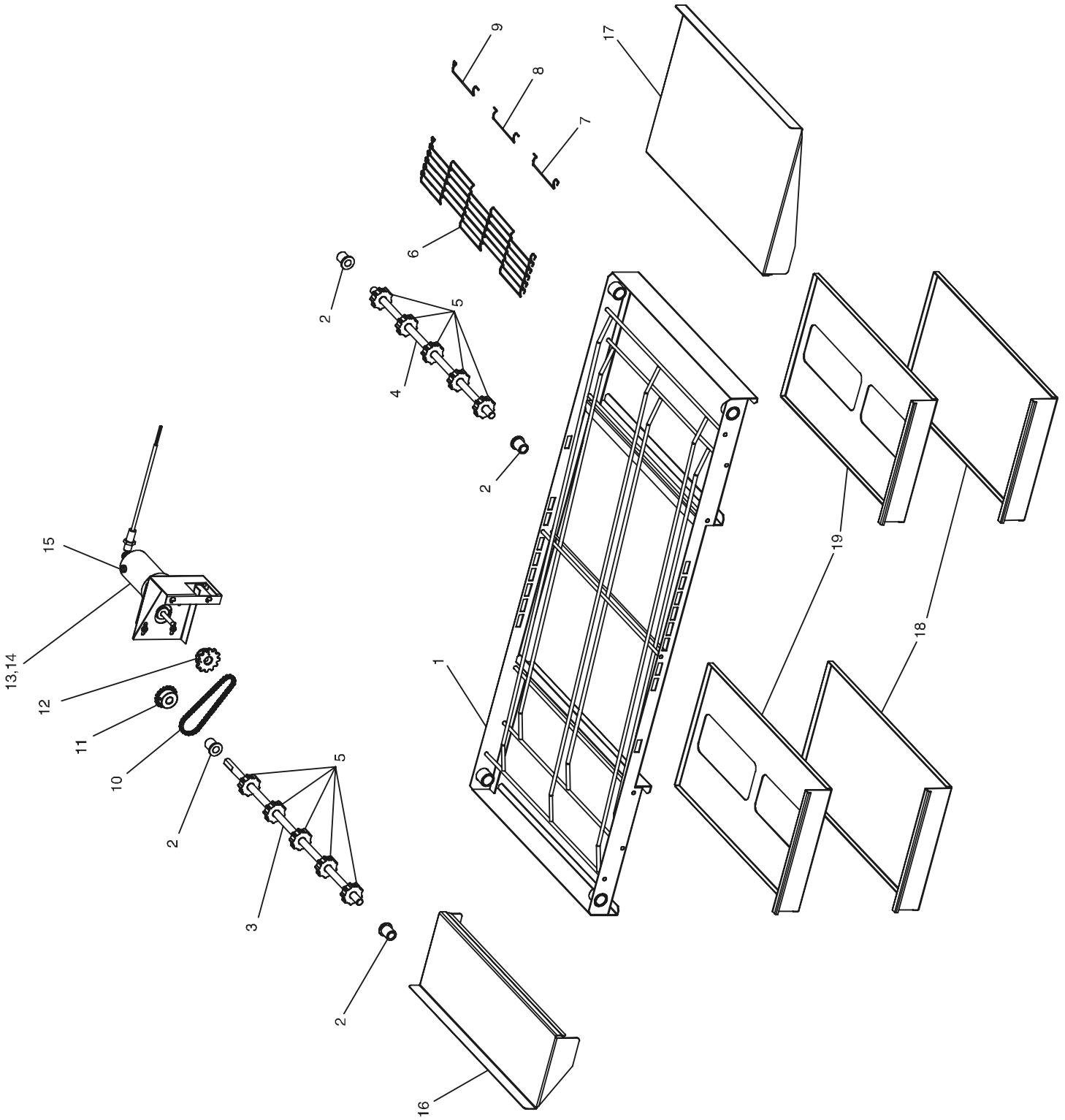

SINGLE CONVEYOR

ITEM	QTY	PART NO.	DESCRIPTION
1	1	48471	WELDMENT
2	4	M4817	BEARING, RULON
3	1	M4815	SHAFT, DRIVE
4	1	51408	SHAFT, IDLER
5	10	M4818	SPROCKET, WIRE BELT
6	1	M7471	BELT, WIRE, STN STL 18" X 7.5' LONG
7	1	50060	LINK, MASTER LEFT 1/2P-18"
8	1	50062	LINK, MASTER CENTER 1/2P-18"
9	1	50061	LINK, MASTER RIGHT 1/2-18
10	1	55567	ASSY, CHAIN HIGH SPEED
10A	1	3101212	LINK, MASTER, #25 CHAIN
10B	1	55566	CHAIN, #25 LINK
11	1	55217	SPROCKET, CHAIN #25-20T-1/2 CONVEYOR SHAFT
12	1	45349	SPROCKET, 25B25 w/5/16 BORE DRIVE MOTOR
13	1	58500	MOTOR, CONVEYOR DRIVE
14	1	50163	KIT, CONVEYOR PICK-UP
15	1	30153	BRUSHES
16	1	51297	EXTENSION, CONVEYOR 6
17	1	51296	EXTENSION, CONVEYOR 12
18	2	48469	PAN, CRUMB
19	2	51409	PAN, CRUMB VENTED (SHIPPED STANDARD)

NOTES

SECTION 7 ELECTRICAL SCHEMATICS

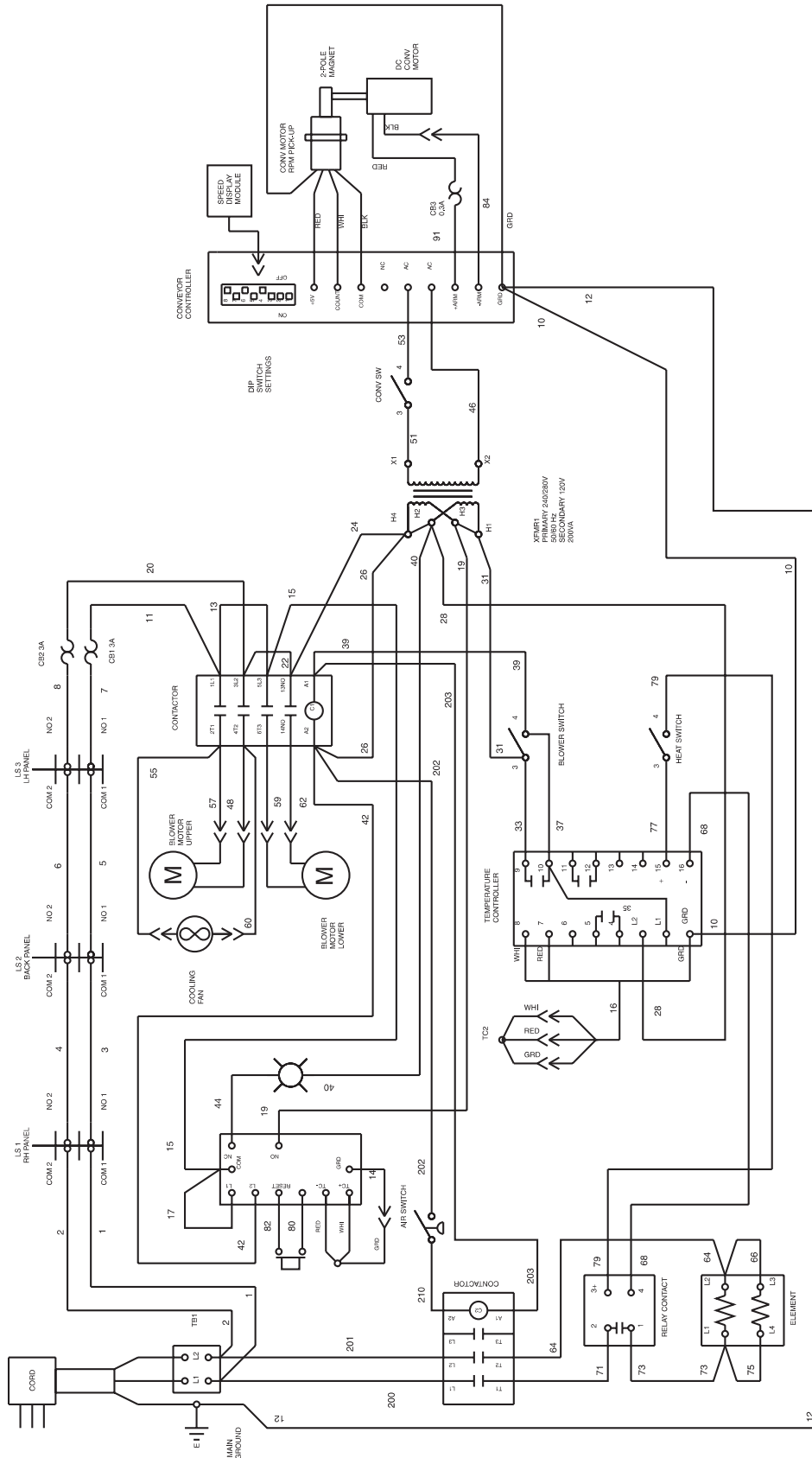

Wiring Diagram, E208-240 50/60/1, PS520

SECTION 7
ELECTRICAL SCHEMATICS

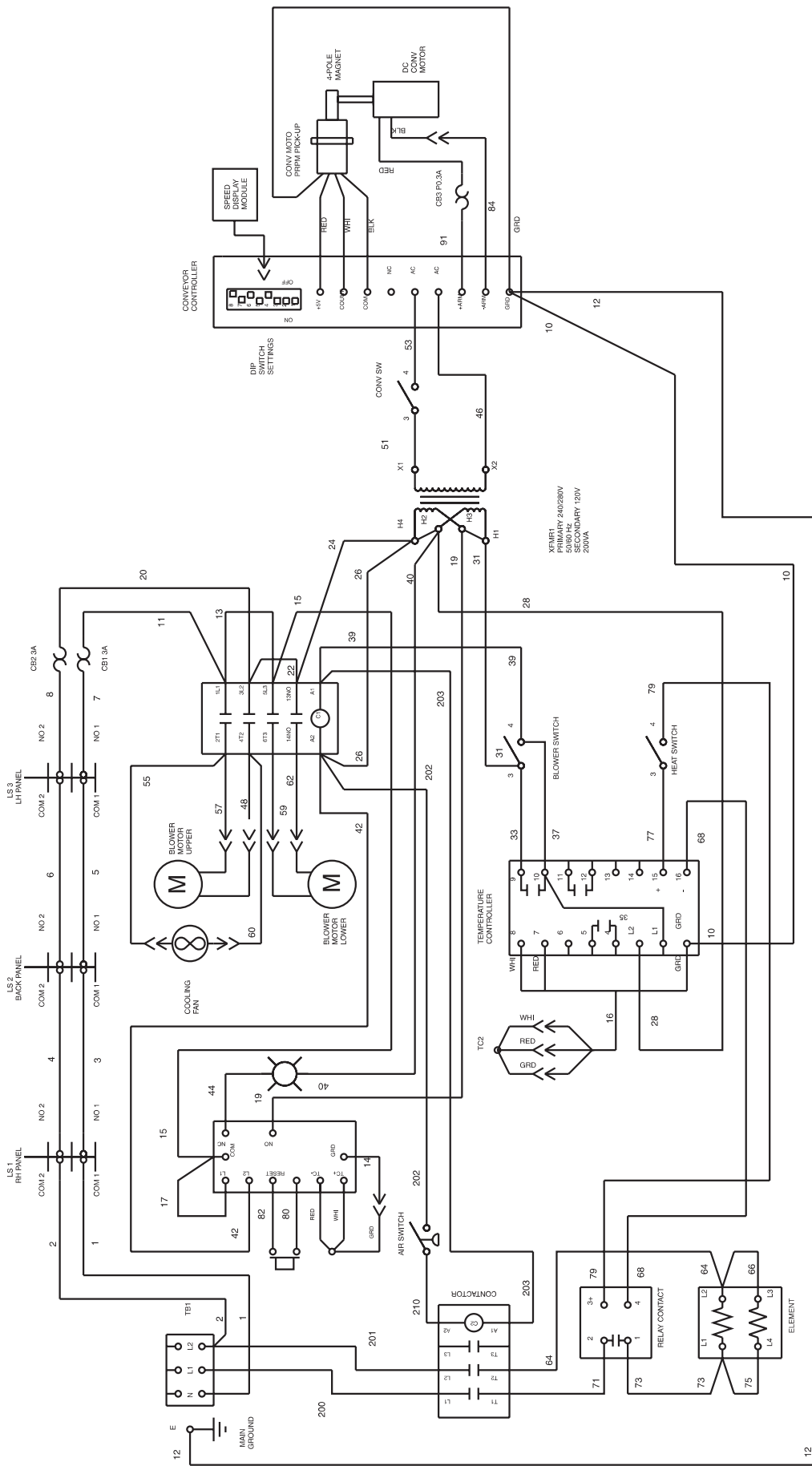

Wiring Diagram, E380-480V 50/60/1, PS520 (Non CE)

SECTION 7 ELECTRICAL SCHEMATICS

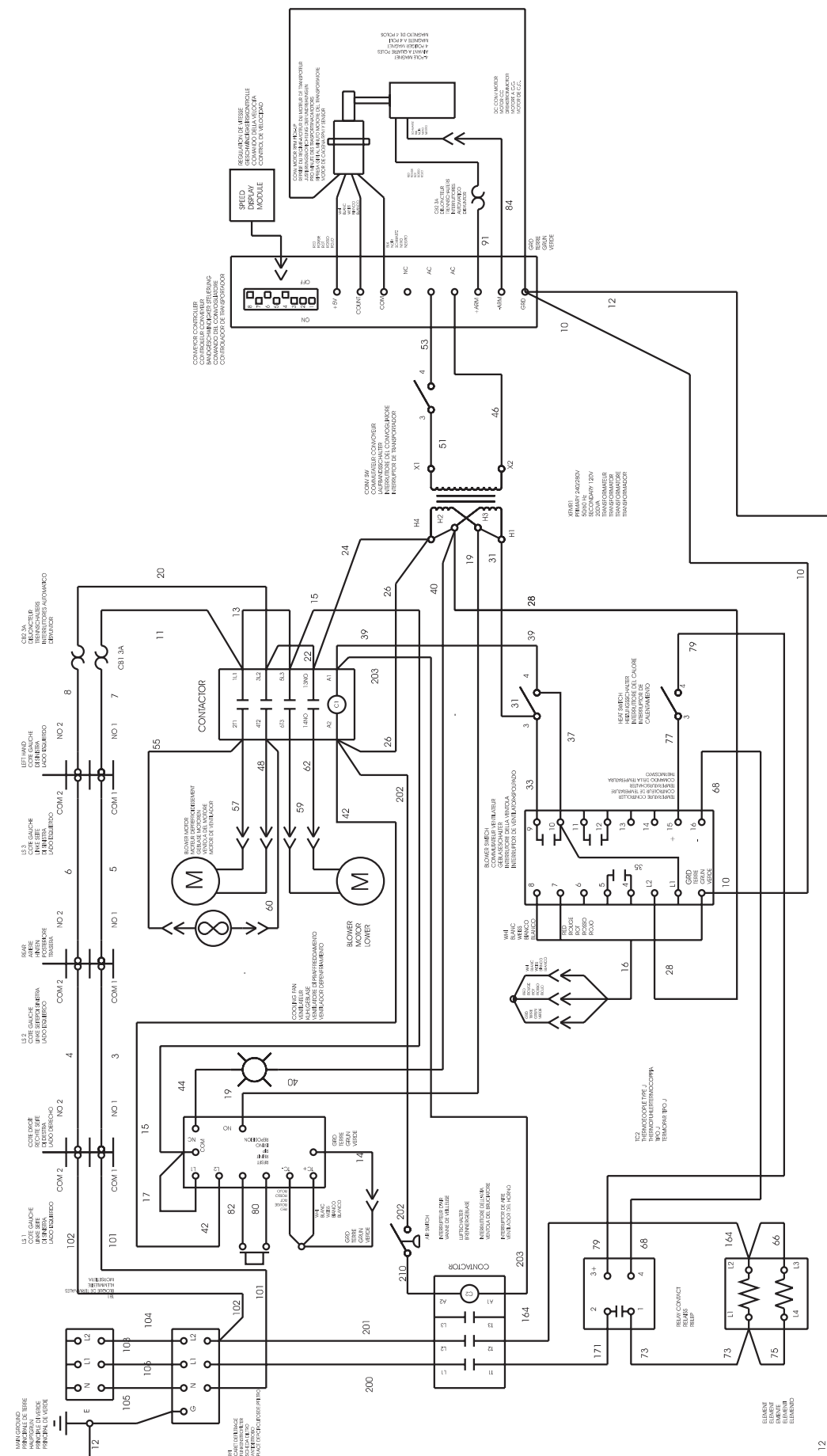

Wiring Diagram, E380-400V CE PS520/1820S

NOTES

WARNING

Improper installation, adjustment, alteration, service or maintenance can cause property damage, injury or death. Read the installation, operating and maintenance instructions thoroughly before installing or servicing this equipment.

NOTICE

During the warranty period, ALL parts replacement and servicing should be performed by your Middleby Marshall Authorized Service Agent. Service that is performed by parties other than your Middleby Marshall Authorized Service Agent may void your warranty.

NOTICE

Using any parts other than genuine Middleby Marshall factory manufactured parts relieves the manufacturer of all warranty and liability.

NOTICE

Middleby Marshall reserves the right to change specifications at any time.

CFESA

Commercial Food Equipment Service Association

Middleby is proud to support the Commercial Food Equipment Service Association (CFESA). We recognize and applaud CFESA's ongoing efforts to improve the quality of technical service in the industry.

Middleby Cooking Systems Group • 1400 Toastmaster Drive • Elgin, IL 60120 • USA • (847)741-3300 • FAX (847)741-4406

www.middleby-marshall.com

